



## **ELECTRIC-POWERED GO-KART**



# **OWNER'S MANUAL**

**Read and understand this entire manual before allowing child to use this product! For assistance contact Razor. DO NOT RETURN TO STORE.**

**NOTE: Manual illustrations are for demonstration purposes only. Illustrations may not reflect exact appearance of actual product. Specifications subject to change without notice.**

**Please have your product along with the 19 character product I.D. code with you before contacting Razor for warranty assistance and/or replacement parts.**

**Product I.D. Code: \_\_\_\_\_ - \_\_\_\_\_ - \_\_\_\_\_**

# CONTENTS

Safety Warnings.....	1-2	Usage.....	9
Before You Begin.....	3	Repair and Maintenance.....	10-11
Assembly and Set-Up.....	4--6	Troubleshooting Guide.....	12
Charging the Battery.....	7	Rad Rod Parts.....	13
Pre-Ride Checklist.....	8	Warranty and Contact Information.....	15

# SAFETY WARNINGS

**! WARNING:** Riding an electric product does present potential risks and caution is required. Certain conditions may cause the equipment to fail without fault of the manufacturer. Like any electric product, the Rad Rod has inherent hazards associated with its use (for example, falling off or riding it into a hazardous situation). Like any electric product, the Rad Rod can and is intended to move and it is therefore, of course, possible to lose control or otherwise get into dangerous situations. Both children and adults responsible for supervising them must recognize that if such things occur, a rider can be seriously injured or die, even when using safety equipment and other precautions. **RIDE AT YOUR OWN RISK AND USE COMMON SENSE.**

This manual contains important safety information. It is your responsibility to review this information and make sure that all riders understand all warnings, cautions, instructions and safety topics and assure that young riders are able to safely and responsibly use this product. Razor recommends that you periodically review and reinforce the information in this manual with younger riders, and that you inspect and maintain your child's product to ensure their safety.

This manual contains many warnings and cautions concerning the consequences of failing to maintain, inspect or properly use your electric product. Because any incident can result in serious injury or even death, we do not repeat the warning of possible serious injury or death each time such a possibility is mentioned.

**! WARNING: PARENTAL AND ADULT RESPONSIBILITY AND SUPERVISION IS NECESSARY:** Because products, like the Rad Rod, can and do present potential hazards plainly associated with their use, it is well recognized THE NEED FOR EXERCISE OF PARENTAL RESPONSIBILITY IN SELECTING ELECTRIC PRODUCTS APPROPRIATE TO THE AGE OF A CHILD, OR PARENTAL SUPERVISION IN SITUATIONS IN WHICH CHILDREN OF VARIOUS AGES MAY HAVE ACCESS TO THE SAME ELECTRIC PRODUCTS, IS IMPORTANT. Not every product is appropriate for every age or size of child, and different age recommendations are found within this category of product which are intended to reflect the nature of the hazards and the expected mental or physical ability, or both, of a child to cope with the hazards.

**! WARNING: PARENT CONTROLLED HIGH/LOW SPEED SWITCH:** The Rad Rod has a HIGH-LOW speed switch which can be manually set by an adult before children ride it. This switch allows parents to reduce the Rad Rod speed for novice riders. See page 5.

Manufacturer's suggested minimum rider age is 8+ in the HIGH speed setting and 6+ in the LOW speed setting. The default setting is HIGH.

**The recommended rider age of six (6) years or older for the Rad Rod is only an estimate and can be affected by the rider's size, weight or skills.** Any rider unable to fit comfortably on the product should not attempt to ride it. **A parent's decision to allow his or her child to ride this product should be based on the child's maturity, skill and ability to follow rules.** Razor emphasizes that adults are strongly advised not to disregard Razor's recommendations or permit younger children to ride the Rad Rod.

**Keep this product away from small children and remember that it is intended for use only by persons who are, at a minimum, completely comfortable and competent while operating the product.**

Persons with any mental or physical conditions that may make them susceptible to injury, impair their physical dexterity or mental capabilities to recognize, understand, and follow safety instructions and to be able to understand the hazards inherent in product use, should not use or be permitted to use products inappropriate for their abilities. Persons with heart conditions, head, back or neck ailments (or prior surgeries to these areas of the body), or pregnant women, should be cautioned not to operate such products.

**DO NOT EXCEED THE WEIGHT LIMIT OF 110 lb (50 kg). Rider weight does not necessarily mean a person's size is appropriate to fit or maintain control of the Rad Rod.**

## CHECK AND MAINTAIN PRODUCT CONDITIONS

Before use, check to confirm that any and all chain guards or other covers and guards are in place and in serviceable condition. Check that the brake is functioning properly, and that tires do not have excess wear. Always inspect product before riding and regularly maintain it. Replace worn or damaged parts immediately. Check brake for proper function. When you press on the hand brake paddle, the brake should provide positive braking action. The product should be maintained and repaired in accordance with the manufacturer's specifications, using only the manufacturer's authorized replacement parts, and should not be modified from the manufacturer's original design and configuration.

## ACCEPTABLE RIDING PRACTICES AND CONDITIONS

**Always check and obey any local laws or regulations which may affect the locations where the Rad Rod may be used. Keep safely away from cars and motor vehicle traffic at all times. Only use where allowed and with caution.**

Ride defensively. Watch out for potential obstacles that could catch your wheel or force you to swerve suddenly or lose control. Be careful to avoid pedestrians, skaters, skateboards, scooters, bikes, children or animals who may enter your path, and respect the rights and property of others.

The Rad Rod is meant to be used on private property and on closed courses and not on public streets or sidewalks. Do not ride your electric product in any areas where pedestrian or vehicle traffic is present.

Do not activate the throttle unless you are on the product and in a safe, outdoor environment suitable for riding.

**The normal (factory set) powered top speed of this product will be approximately 10 mph (16 km/h) and the parent controlled HIGH-LOW speed switch can be set to a lower speed of 7 mph (11.3 km/h), which can be affected by conditions, such as rider weight, inclines and battery charge level.**

Do not attempt or do stunts or tricks on your electric Rad Rod. The Rad Rod is not made to withstand abuse from misuse, such as jumping, curb grinding or any other type of stunts. Racing, stunt riding, or other maneuvers also enhance risk of loss of control, or may cause uncontrolled rider actions or reactions.

# SAFETY WARNINGS

This product was manufactured for performance and durability but is not impervious to damage. Jumping or other aggressive riding can overstress and damage any product, including the Rad Rod, and the rider assumes all risks associated with high-stress activity.

Be careful and know your limitations. Risk of injury increases as the degree of riding difficulty increases. The rider assumes all risk associated with aggressive riding activities.

Maintain a hold on the steering wheel at all times.

Never carry passengers or allow more than one person at a time to ride the electric product.

Never use near steps or swimming pools.

Do not allow hands, feet, hair, body parts, clothing, or similar articles to come in contact with moving parts of the product, wheels, drive train, or chain while the motor is running.

Do not touch the brake or electric motor on your electric product when in use as they can become very hot.

Never use headphones, a cell phone or text when riding.

Never hitch a ride with a vehicle.

Do not ride the Rad Rod in wet or icy weather and never immerse the electric product in water, as the electrical and drive components could get damaged by water or possibly create other unsafe conditions.

The electric Rad Rod is intended for use on flat, dry surfaces, such as pavement or level ground, without loose debris, such as sand, leaves, rocks or gravel. Wet, slick, bumpy, uneven or rough surfaces may impair traction, increase risks and contribute to possible accidents. Do not ride the electric product in mud, ice, puddles or water. Avoid sharp bumps, drainage grates, and sudden surface changes. Avoid excessive speeds that can be associated with downhill rides.

Never risk damaging surfaces such as carpet or flooring by use of an electric product indoors.

Do not ride at night or when visibility is limited.

## PROPER RIDING ATTIRE

Always wear proper protective equipment such as an approved safety helmet (with chin strap securely buckled). A helmet may be legally required by local law or regulation in your area. Elbow pads and kneepads, a long-sleeved shirt, long pants and gloves are recommended. Always wear athletic shoes (lace-up shoes with rubber soles) and keep shoelaces tied and out of the way of the wheels, motor and drive system. Never ride barefooted or in sandals.

## USING THE CHARGER

The charger supplied with the electric product should be regularly examined for damage to the cord, plug, enclosure and other parts. In the event of such damage, the product must not be charged until the charger has been repaired or replaced.

Use only with the recommended charger.

Use caution when charging.

The charger is not a toy. Charger should be operated by an adult.

Do not operate charger near flammable materials.

Unplug charger and disconnect from product when not in use.

Do not exceed charging time.

Always disconnect from the charger prior to wiping down and cleaning your product with damp cloth.

**FAILURE TO USE COMMON SENSE AND HEED THE ABOVE WARNINGS INCREASES RISK OF SERIOUS INJURY. USE AT YOUR OWN RISK AND WITH APPROPRIATE AND SERIOUS ATTENTION TO SAFE OPERATION. USE CAUTION.**

# BEFORE YOU BEGIN

Remove contents from box. Remove the separators that protect the components from damage during shipping. Inspect the contents of the box for scratches in the paint, dents or kinked cables that may have occurred during shipping. Because the Rad Rod was 95 percent assembled and packed at the factory, there should not be any problems, even if the box has a few scars or dents.

**MAKE SURE POWER SWITCH IS TURNED "OFF" BEFORE CONDUCTING ANY ASSEMBLY OR MAINTENANCE PROCEDURES.**

## Estimated Assembly and Set-Up Time

Razor recommends assembly by an adult.

Allow up to 20 minutes for assembly, not including initial charge time.

Allow up to 12 hours for initial charge (**see page 7 for charging information**).

**! WARNING: DO NOT USE NON-RAZOR PARTS WITH YOUR PRODUCT.** The Rad Rod has been built to certain Razor design specifications. The original equipment supplied at the time of sale was selected on the basis of its compatibility with the frame and all other parts. Certain aftermarket components may not be compatible and will void the warranty.

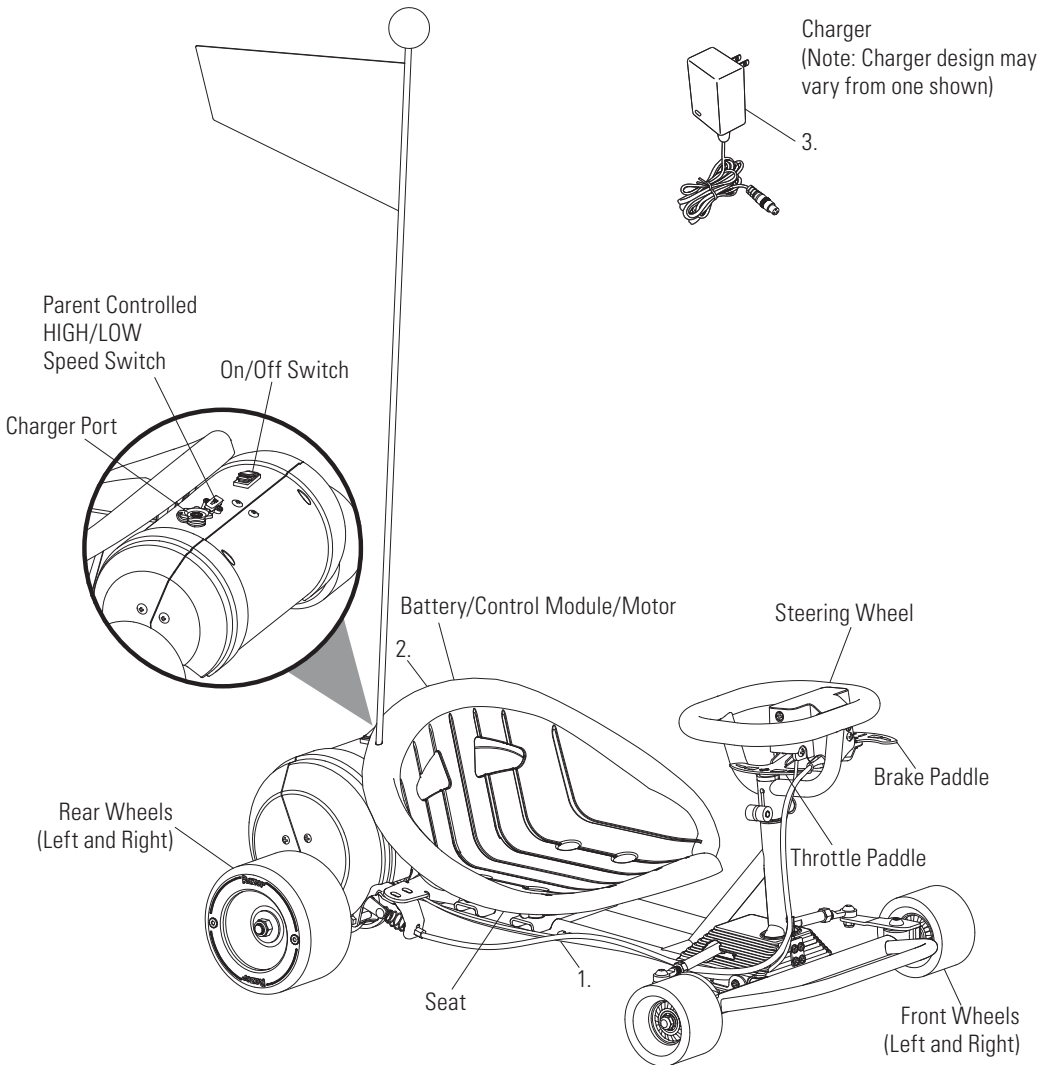

### Product ID Locations:

(See locations to the left)

1. Underneath Frame
2. Back of Seat
3. Charger
4. UPC Side of Box (Not Shown)

## Required Tool

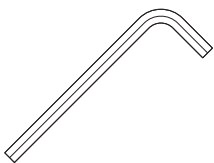

5 mm Allen Wrench  
(included)

### Plastic Bag Contents:

- Charger
- Allen Wrench
- Owner's Manual

# ASSEMBLY AND SET-UP

Turn power switch off before conducting any assembly or maintenance procedures.

## □ Attaching the Steering Wheel

**Required Tool:** 5 mm Allen Wrench (included)

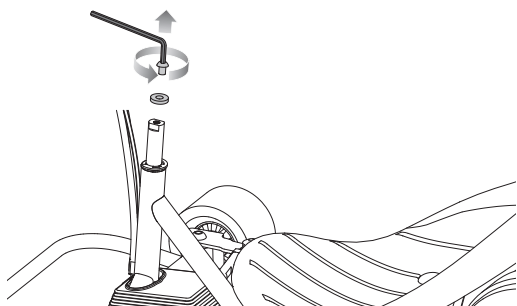

**1** Using a 5 mm Allen wrench, remove the steering wheel axle bolt and washer.

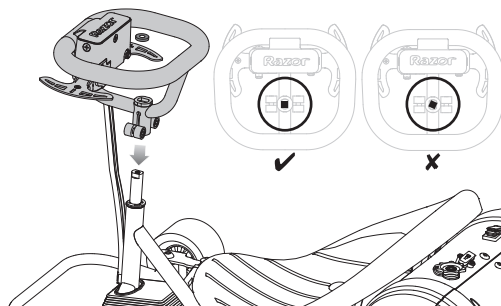

**2** Lower the steering wheel onto the axle. Make sure the limiter is straight and parallel to the steering axle. The limiter should not be rotated.

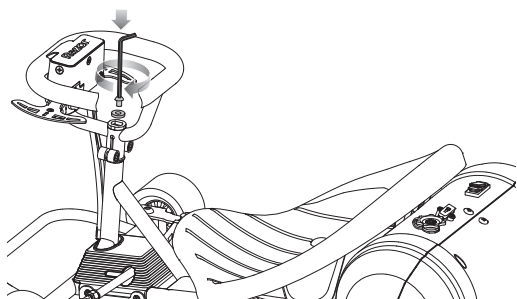

**3** Using a 5 mm Allen wrench, replace the steering wheel axle bolt and washer that were removed in step 1. Tighten securely.

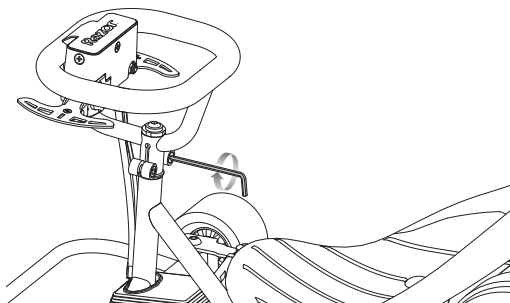

**4** Using a 5 mm Allen wrench, tighten the bolts on either side of the steering wheel base.

**! WARNING:** Failure to properly install and tighten the bolts and washer that affix the steering wheel can cause you to lose control and crash.

# ASSEMBLY AND SET-UP

## ☐ Parent Controlled HIGH/LOW Speed Switch

**Required Tool:** Phillips Screwdriver (not included)

The Rad Rod features a speed control switch that allows parents to discreetly reduce (or raise) the Rad Rod's top speed. This limiter is intended for parents of younger children and those needing extra practice time to learn how the Rad Rod moves. It is recommended that all riders use the LOW setting while learning how to operate the Rad Rod. Once the rider is comfortable with using the Rad Rod in the LOW setting, and has acquired the necessary skills to safely ride the Rad Rod, the parent has the option to change the setting to the HIGH setting.

The switch is inside the Rad Rod's speed control switch cover, such that riders cannot access it without using a Phillips screwdriver. There are two settings:

- When the switch is in the **HIGH** position, the Rad Rod has a top speed of 10 mph (16 km/h). This is the default setting and recommended for riders age 8 and older.
- When the switch is in the **LOW** position, the Rad Rod's top speed is limited to 7 mph (7 km/h) and the recommended minimum rider age is 6 years old.

**Note:** The red speed switch is located next to the charger port.

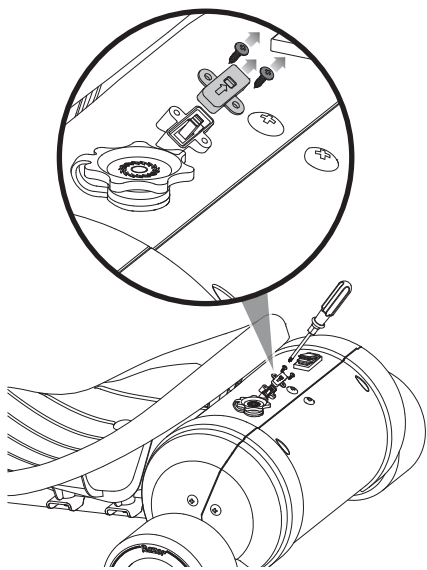

**1** Using a Phillips screwdriver, remove the two (2) screws and cover on the HIGH/LOW Speed Switch.

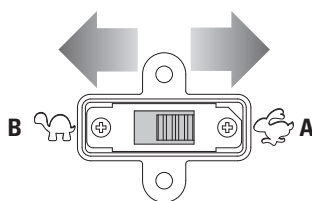

**2** Adjust the speed setting by sliding the switch to the right for HIGH speed (ages 8+) (**A**) or left for the LOW speed (ages 6+) (**B**).

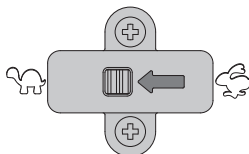

**3** Using a Phillips screwdriver, reinstall the two (2) screws and cover on the HIGH/LOW Speed Switch that were removed in step 1.

# ASSEMBLY AND SET-UP

## □ Attaching the Flag



**1** Assemble flag as shown.

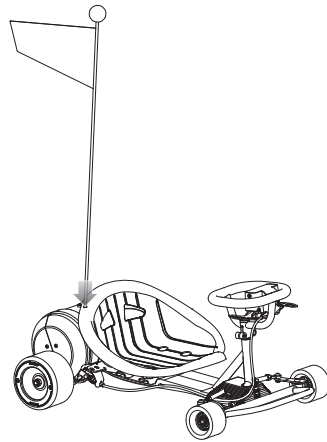

**2** Insert flag all the way into the bottom of the fixed hole located on the top of the seat back.

# CHARGING THE BATTERY

**Your Rad Rod may not have a fully charged battery; therefore you must charge the battery prior to use.**

- Initial charge time: 12 hours.
- Recharge time: up to 8 hours, even if the light turns green. Recommended maximum charging time is 24 hours.
- Always charge the battery immediately after riding.
- Fully charge battery before storing for extended periods of time.
- Unplug charger from the wall outlet when not in use.
- Failure to recharge battery periodically may result in a battery that will not accept a charge.

- Make sure the Rad Rod's power is turned **OFF** when product is not in use. If the power switch is left on for an extended period of time, the battery may reach a stage at which it will no longer hold a charge.
- To ensure long battery life, never store the product in freezing or below freezing temperatures! Freezing will permanently damage the battery.
- Run time: Up to 40 minutes of continuous ride time. Run time may vary depending on riding conditions, rider weight, climate, and/or proper maintenance.
- Constant starting and stopping may shorten ride time.

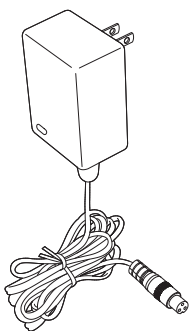

Charger

**Note:** Charger design may vary from one shown.

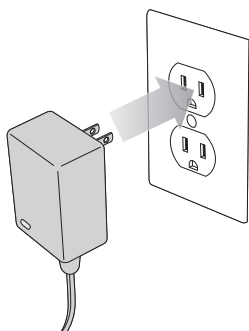

**1** Plug the charger plug into wall outlet. The light on the charger should be green.

**Note:** If green light (LED) does not turn on, try a different outlet.

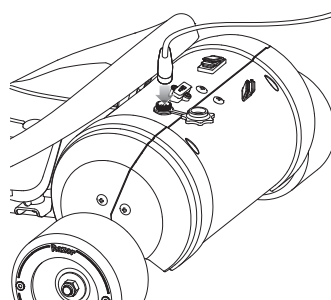

**2** Make sure the power switch is in the **OFF** position. Plug the charger into the charger port on the Rad Rod. The light on the charger should turn red during charging. The light will turn green again when charging is complete.

**! WARNING:** Use **ONLY** with the recommended charger. Batteries are only to be charged under adult supervision. The charger is not a toy. Always disconnect the charger before wiping down and/or cleaning the Rad Rod with a damp cloth.

The charger supplied with the Rad Rod should be regularly examined for damage to the cord, plug, enclosure and other parts. In the event of such damage, the Rad Rod must not be charged until it has been repaired or replaced.

Chargers have built-in overcharge protection to prevent battery from being overcharged.

**Note:** If the charger gets warm during regular use, this is a normal response and is no cause for concern. If your charger does not get warm during use, it does not mean that it is not working properly.

Wall outlet - Green (stand by)  
Wall outlet and unit - Red (charging)  
Wall outlet and unit - Green (charged)

**Note:** Continue charging unit even if light turns green prior to 8 hours.

**! WARNING:** Battery charge can deplete over time. Periodically recharge battery when not in use.

Model	Voltage (Nominal) Vdc	Capacity (Nominal) Ah	Charge Temperature Range	Operating Temperature Range
Rad Rod	24	2.8	0° to 40°C 32° to 104°F	-20° to 40°C -4° to 122°F

**Need Help?** Visit our website for replacement parts, product support, a list of authorized service centers in the US and customer service contact information at [www.razor.com](http://www.razor.com). Please have the product I.D. code (located on the white label of your product) available for better assistance. Additional Customer Service contact information is listed at the back of this manual.



# PRE-RIDE CHECKLIST



## Brake

Check the brake for proper function. When you press on the hand brake paddle, the brake should provide positive braking action. When you apply the brake with the hand throttle paddle on/engaged, the brake cut-off switch will stop the motor.



## Wheels

Periodically inspect the wheels for excess wear. Practice riding only in wide open areas clear from curbs, parking blocks and other obstacles. Impacting the wheels against any hard surface can damage the wheels. Wheels are not covered under your limited warranty.



## Frame, Fork and Steering Wheel

Check for cracks or broken connections. Although broken frames are rare, it is possible for an aggressive rider to run into a curb or object, and wreck and bend or break a frame. Get in the habit of inspecting your Rad Rod on a regular basis.



## Hardware/Loose Parts

Before every ride, check all parts, such as nuts, bolts, cables, fasteners, etc., to ensure they are secure and assembled correctly. There should not be any unusual rattles or sounds from loose parts or broken components. If the product is damaged, do not ride. **Reference "Safety Warnings" on pages 1 and 2 of this manual.**



## Safety Gear

Always wear proper protective equipment, such as an approved safety helmet (with chin strap securely buckled), elbow pads, and kneepads. A helmet may be legally required by local law or regulation in your area. A long-sleeved shirt and long pants are recommended. Always wear shoes and keep shoelaces tied and out of the way of the wheels and drive system. **NEVER RIDE BAREFOOTED OR IN SANDALS.**



## Insurance

Do not assume that your existing insurance policies necessarily provide coverage for electric product use. Check with your insurance company for information regarding insurance.



## Storage

Prolonged exposure to UV rays, rain and the elements may damage the enclosure materials, store indoors when not in use.



## Laws and Regulations

Always check and obey any local laws or regulations.

# USAGE

## □ How to Start

Do not activate (press on) the hand throttle paddle unless you are in the product and in a safe, outdoor environment suitable for riding.

To start the product, position your body in the seat and place feet on the foot bar (A). Turn power switch to the **ON** position (B).

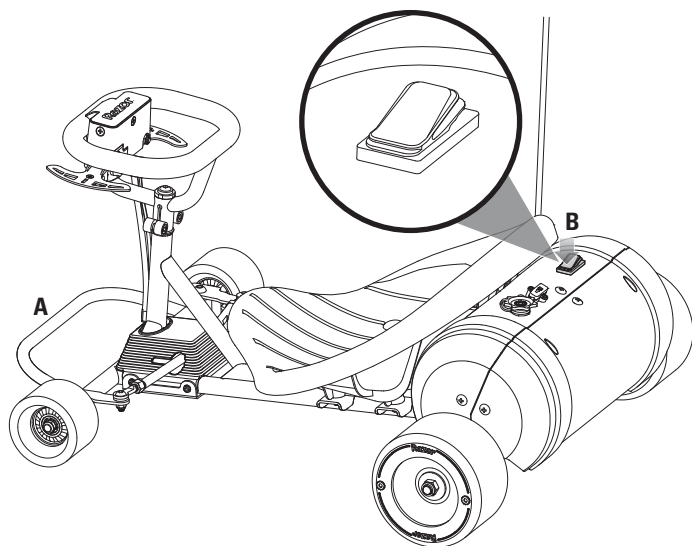

## □ How to Drive

Accelerate with your right hand by pulling up on the hand throttle paddle with the + symbol (C) to move forward. Brake with your left hand by pulling up on the hand brake paddle with the - symbol (D). Hold the steering wheel (E) with both hands, at all times, to control direction and turning. Razor recommends that you practice driving in an open area free from obstructions before riding your product around others.

**Note:** Keep both hands on the steering wheel and both feet on the foot bar (A) when product is in motion.

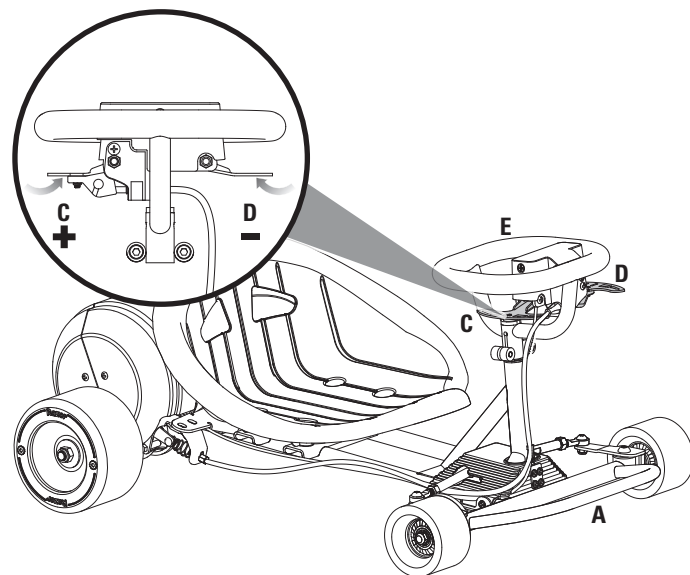

## □ How to Stop

To stop the product, release the throttle (C) apply the brake, by pulling up on the hand brake paddle (D), until the product comes to a complete stop. Razor recommends that you practice applying the brake at various speeds and in an open area free from obstructions before riding your product around others. Make sure to press the power switch to the **OFF** position after you complete your ride.

**Note:** The brake paddle contains a safety switch to cut off power to the motor when the brake is applied. In an emergency, applying the brake will always stop the product from moving.

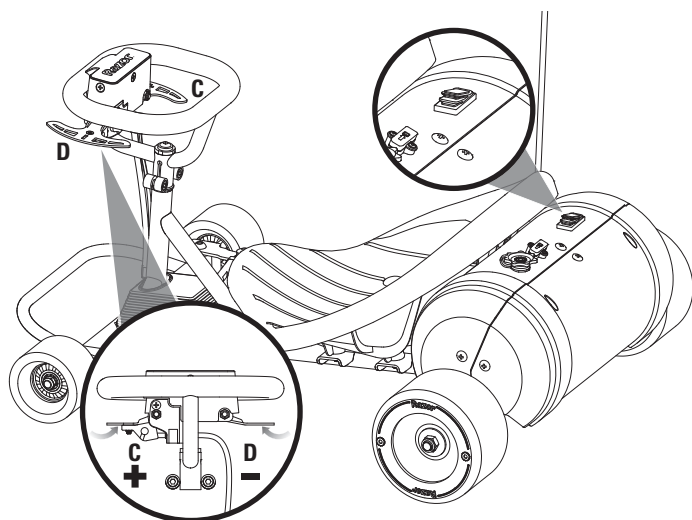

**Need Help?** Visit our website for replacement parts, product support, a list of authorized service centers in the US and customer service contact information at [www.razor.com](http://www.razor.com). Please have the product I.D. code (located on the white label of your product) available for better assistance. Additional Customer Service contact information is listed at the back of this manual.

# REPAIR AND MAINTENANCE

Turn power switch "OFF" before conducting any maintenance procedures.

- Read the instructions.
- Secure the product under repair.
- Contact Razor customer service if unsure about any repair or maintenance.
- Remove charger plug.
- Exercise caution around exposed parts.
- Repair and maintenance should be performed by an adult only.
- Turn the power switch **OFF**.

## ❑ Replacing the Front Wheels

**Required Tool:** 13 mm Socket Wrench (not included)

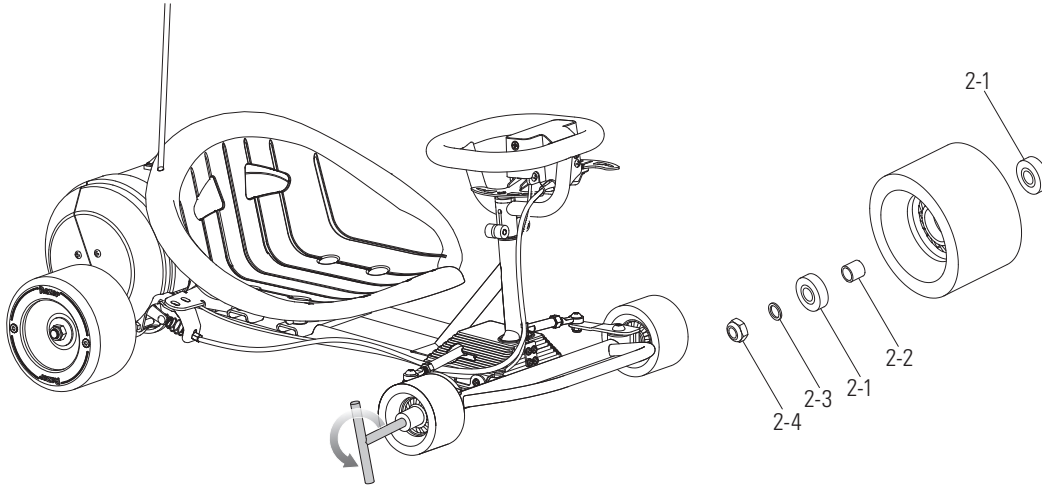

Using a 13 mm socket wrench, loosen the axle bolt. Remove wheel and install replacement wheel. (Note the sequence of the hardware)

**⚠ WARNING:** Failure to properly adjust and tighten the screws, nuts and bolts that affix the wheels can cause you to lose control and crash.

**Note:** Practice riding only in wide open areas clear from curbs, parking blocks and other obstacles. Impacting the wheels against any hard surface can damage the wheels. Wheels are not covered under your limited warranty.

2-1 Bearing

### Wheel

2-2 Spacer  
2-1 Bearing  
2-3 Washer  
2-4 Lock Nut

# REPAIR AND MAINTENANCE

## ❑ Cleaning Your Rad Rod

Wipe with a damp cloth to remove dirt and dust. Do not use industrial cleaners or solvents as they may damage the surfaces. Do not use alcohol, alcohol-based or ammonia-based cleaners as they may damage or dissolve the plastic components or soften the decals or decal adhesive.

## ❑ Battery Care and Disposal

The battery is not intended to be replaced by the user. Razor recommends you consult a Razor repair center for battery replacement.

Do not store in freezing or below freezing temperatures. To properly maintain your battery and ensure maximum battery life, carefully read the "Charging the Battery" section on page 7 of this owner's manual.



CONTAINS SEALED LEAD-ACID BATTERIES. BATTERIES MUST BE RECYCLED.

**Disposal:** Your Razor product uses sealed lead-acid batteries which must be recycled or disposed of in an environmentally safe manner. Do not dispose of a lead-acid battery in a fire. The battery may explode or leak. Do not dispose of a lead-acid battery in your regular household trash. The incineration, land filling or mixing of sealed lead-acid batteries with household trash is prohibited by law in most areas. Return exhausted batteries to a federal or state approved lead-acid battery recycler or a local seller of automotive batteries. If you live in Florida or Minnesota, it is prohibited by law to throw away lead-acid batteries in the municipal waste stream.

## ❑ Charger

The charger supplied with the Rad Rod should be regularly examined for damage to the cord, plug, enclosure and other parts, and in the event of such damage, the product must not be charged until it has been repaired or replaced.

Use ONLY with the recommended charger.

## ❑ Wheels

Wheels and drive system are subject to normal wear and tear. It is the responsibility of the user to periodically inspect wheels for excess wear and adjust and replace drive train components as required.

## ❑ Replacement Parts

The most frequently requested replacement parts are available for purchase at some Razor retail partners. For the complete selection of replacement parts visit [www.razor.com](http://www.razor.com).

## ❑ Repair Centers

For a list of authorized Razor repair centers:

- Check online at [www.razor.com](http://www.razor.com).
- Additional Customer Service contact information is listed on the back of this manual.



### In the US and Canada only:

For more information regarding recycling of rechargeable batteries, call toll free 1-800-822-8837, or visit <http://www.call2recycle.org>

**! WARNING:** If a battery leak develops, avoid contact with leaking acid and place the damaged battery in a plastic bag. Refer to the disposal instructions at left. If acid comes into contact with skin or eyes, flush with cool water for at least 15 minutes and contact a physician.

**! WARNING:** Battery posts, terminals and related accessories contain lead and lead compounds. **Wash your hands after handling.**

# TROUBLESHOOTING GUIDE

\*Unit(s) should be turned **OFF** and fully charged prior to doing any Troubleshooting  
**NOTE:** All troubleshooting steps should be performed by an adult only.

Problem	Possible Cause	Solution
Product does not run.	Undercharged battery.	Charge the battery. A new battery should have been charged for at least 12 hours before using the product for the first time and up to 8 hours after each subsequent use.  Check all connectors. Make sure the charger connector is tightly plugged into the charging port and that the charger is plugged into a functioning wall outlet.
	Charger is not working.	Contact Razor Customer Service to get replacement charger.
	Prolonged riding under overloaded conditions or in high temperature weather/ environmental conditions.	Motor may activate high temperature protection; motor must cool down before riding or charging can resume.
Product was running but suddenly stopped.	Loose wires or connectors.	Check all wires and connectors to make sure they are tight.
Product was running but suddenly stopped and light on power switch does not illuminate.	Fuse has tripped.	Replace fuse with 20A fuse in fuse box located next to the battery.
Short run time.	Undercharged battery.	Charge the battery. A new battery should have been charged for at least 12 hours before using the product for the first time and up to 8 hours after each subsequent use.
	Battery is old and will not accept full charge.	Even with proper care, a rechargeable battery does not last forever. Average battery life is 1 to 2 years depending on product use and conditions. Contact Razor customer service or visit <a href="http://www.razor.com">www.razor.com</a> .
Product runs sluggishly.	Riding conditions are too stressful.	Use only on solid, flat, clean and dry surfaces such as pavement or level ground.
	Product is overloaded.	Make sure you do not overload the product by allowing more than one rider at one time, exceeding the maximum weight limit, going up too steep a hill or towing objects behind the product.
Sometimes the product doesn't run, but other times it does.	Loose wires or connectors.	Check all wires and connectors to make sure they are tight.
	Motor or electrical switch damage.	Contact your local Razor authorized service center for diagnosis and repair. Contact Razor customer service or visit <a href="http://www.razor.com">www.razor.com</a> .
Charger gets warm during use.	Normal response to charger use.	No action required. This is normal for some chargers and is no cause for concern. If your charger does not get warm during use, it does not mean that it is not working properly.
Product makes loud noises or grinding sounds.	Chain is too dry.	Apply a bicycle chain lubricant to the chain.

For more troubleshooting tips, a list of available replacement parts or to locate an authorized Service Center in your area, visit our website at [www.razor.com](http://www.razor.com) or call toll free +1 866 467 2967 to speak to a live Customer Service Representative

**Need Help?** Visit our website for replacement parts, product support, a list of authorized service centers in the US and customer service contact information at [www.razor.com](http://www.razor.com). Please have the product I.D. code (located on the white label of your product) available for better assistance. Additional Customer Service contact information is listed at the back of this manual.

# RAD ROD PARTS

Keep your Rad Rod running for years with genuine Razor parts. Visit our website or e-mail us for more information on spare part availability. (Specifications subject to change without notice.)

- |  |                           |   |  |
|--|---------------------------|---|--|
| 1. Steering Wheel                          | 6. Rear Wheels (Set of 2) | 10. Chain Guard                         | 15. Battery Cover                      |
| 2. Wheels (See p. 9 for hardware sequence) | 7. Chain Tensioner        | 11. Chain                               | 15-1 High/Low Speed Switch             |
| 3. Spindle Arm (Right and Left)            | 8. Seat                   | 12. Control Module                      | 15-2 Charger Port                      |
| 4. Steering Assembly                       | 9. Rear Axle              | 13. Motor                               | 15-3 On/Off Switch                     |
| 5. Steering Cover                          | 9-1 Chain Sprocket        | 14. Battery (2x 12v2.8Ah) with 20A Fuse | 15-4 Protective Cover (Left and Right) |
|  | 9-2 Brake Drum            |   | 16. Battery Cover                      |
|  |                           |   | 17. Flag                               |

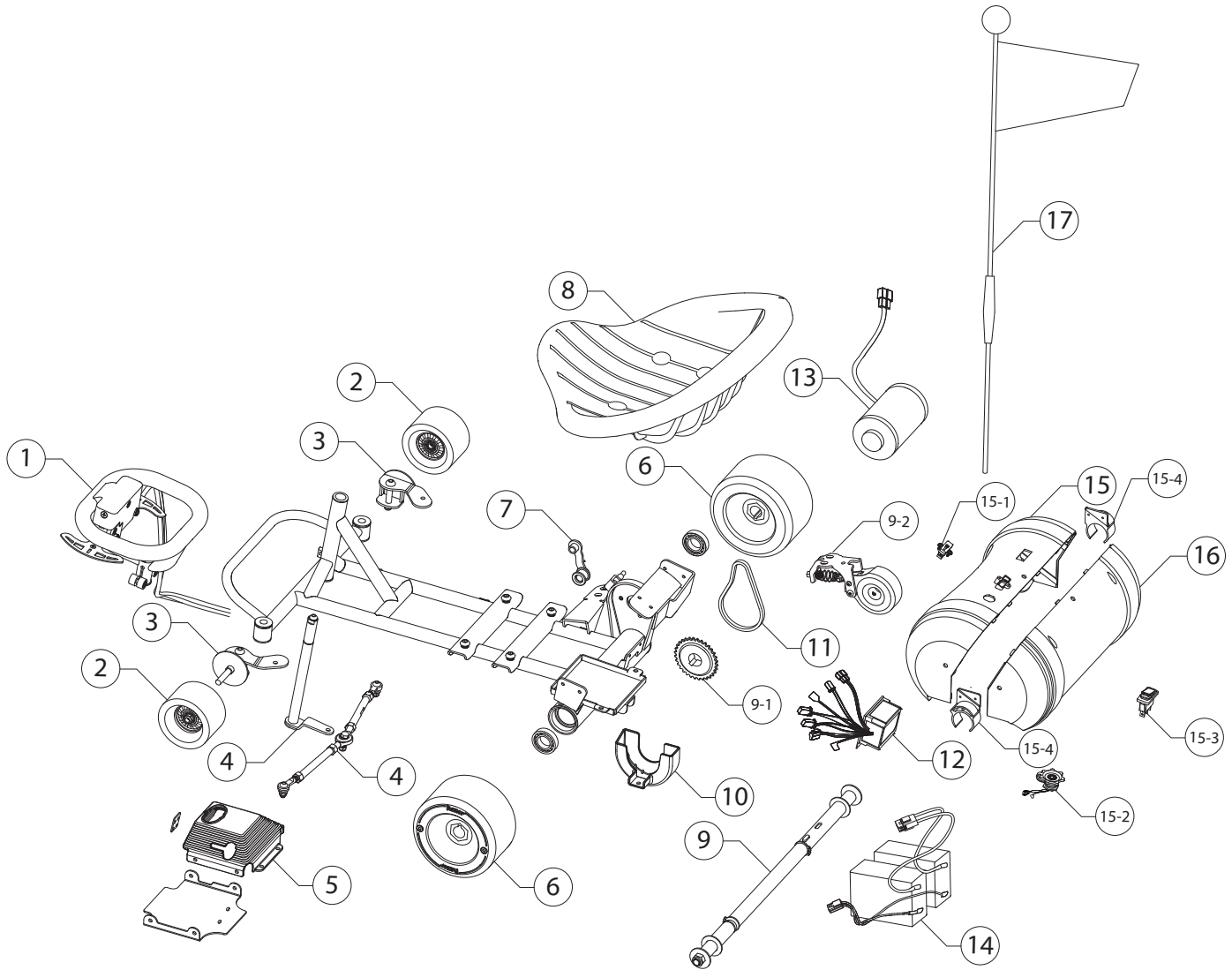

**Need Help?** Visit our website for replacement parts, product support, a list of authorized service centers in the US and customer service contact information at [www.razor.com](http://www.razor.com). Please have the product I.D. code (located on the white label of your product) available for better assistance. Additional Customer Service contact information is listed at the back of this manual.

**NOTICE: INSURANCE**

**YOUR INSURANCE POLICIES MAY NOT PROVIDE COVERAGE FOR ACCIDENTS INVOLVING THE USE OF THIS SCOOTER/ELECTRIC RIDE-ON PRODUCT. TO DETERMINE IF COVERAGE IS PROVIDED, YOU SHOULD CONTACT YOUR INSURANCE COMPANY OR AGENT.**

## FCC COMPLIANCE

This device complies with Part 15 of the FCC Rules. Operation is subject to the following two conditions: (1) This device may not cause harmful interference, and (2) this device must accept any interference received, including interference that may cause undesired operation.

**Note:** This equipment has been tested and found to comply with the limits for a Class B digital device, pursuant to part 15 of the FCC Rules. These limits are designed to provide reasonable protection against harmful interference in a residential installation. This equipment generates, uses and can radiate radio frequency energy and, if not installed and used in accordance with the instructions, may cause harmful interference to radio communications. However, there is no guarantee that interference will not occur in a particular installation. If this equipment does cause harmful interference to radio or television reception, which can be determined by turning the equipment off and on, the user is encouraged to try to correct the interference by one or more of the following measures:

- Reorient or relocate the receiving antenna.
- Increase the separation between the equipment and receiver.
- Connect the equipment into an outlet on a circuit different from that to which the receiver is connected.
- Consult the dealer or an experienced radio/TV technician for help.

**⚠ WARNING:** Changes or modifications to this product not expressly approved by Razor USA LLC, could void the user's authority to operate the equipment.

## WARRANTY

### Razor Limited Warranty

The manufacturer warrants this product to be free of manufacturing defects for a period of 90 days from date of purchase. This Limited Warranty does not cover normal wear and tear, wheel, or any damage, failure or loss caused by improper assembly, maintenance, storage or use of the Razor Rad Rod.

This Limited Warranty will be void if the product is ever:

- used in a manner other than for recreation or transportation;
- modified in any way;
- rented.

The manufacturer is not liable for incidental or consequential loss or damage due directly or indirectly to the use of this product.

Razor does not offer an extended warranty. If you have purchased an extended warranty, it must be honored by the insurance provider from which it was purchased.

For your records, save your original sales receipt with this manual and write the serial number below.

-----

## CUSTOMER SERVICE CONTACT INFORMATION

**Need Help?** Visit our website for replacement parts, product support, a list of authorized service centers in the US and customer service contact information at [www.razor.com](http://www.razor.com). Please have the product I.D. code (located on the white label of your product) available for better assistance. Additional Customer Service contact information is listed below:

### AMERICAS

Razor USA LLC  
P.O. Box 3610  
Cerritos, CA 90703  
USA

+1 866 467 2967  
Monday - Friday  
8:00 AM - 5:00 PM Pacific Time  
[customersupport@razorusa.com](mailto:customersupport@razorusa.com)

### EUROPE, MIDDLE EAST, AFRICA

Razor USA LLC (Europe)  
Handelsweg 2  
2742 RD Waddinxveen  
Netherlands

+44 (0) 120 267 2702  
[info@razoreu.com](mailto:info@razoreu.com)

### ASIA

Razor USA LLC (Asia)  
P.O. Box 3610  
Cerritos, CA 90703  
USA

+81 50 7579 6622  
[info@razor-asia.com](mailto:info@razor-asia.com)

### UNITED KINGDOM AND IRELAND

Razor USA LLC (UK)  
Unit 20  
Hartnoll Business Centre  
Post Hill, Tiverton  
Devon EX16 4NG  
UK

+44 (0) 120 267 2702  
[info@razoreu.com](mailto:info@razoreu.com)

### AUSTRALIA AND NEW ZEALAND

Razor USA LLC  
P.O. Box 4280  
Auburn South  
VIC 3122  
Australia

+1 800 954 354 (AU)  
+0 800 003 221 (NZ)  
[info@razoranz.com](mailto:info@razoranz.com)

### IMPORTED IN JAPAN BY B-PLUS ASIA CORP.

Razor USA LLC  
**THE RIBSTIK COMPANY**  
Kurokawa 3-1, Asaoku,  
Kawasaki, Kanagawa  
215-0035 JAPAN

+81 (0) 44 328 9057 Tel  
+81 (0) 44 328 9067 Fax  
[info@razor-asia.com](mailto:info@razor-asia.com)

Printed in China for Razor USA LLC.

Copyright © 2003-2024 Razor USA LLC. All rights reserved. Ground Force®, Razor® and the Razor logo design are among the registered trademarks of Razor USA LLC in the United States and/or select foreign countries. Rad Rod is a trademark of Razor USA LLC.