

Required Tools: (Not included)

- | | |
|-------------------------|----------------------------------|
| A. 5 mm Allen Wrench | E. Two (2) 17 mm Socket Wrenches |
| B. 3 mm Allen Wrench | F. 10 mm Open-End Wrench |
| C. Phillips Screwdriver | G. C Clip Pliers |
| D. Long Needle Pliers | |

⚠ WARNING

⚠ CAUTION: To avoid potential shock or other injury, turn power switch **OFF** and disconnect charger before conducting any assembly or maintenance procedures. Failure to follow these steps in the correct order may cause irreparable damage.

Step 1

Remove the flag and use a 5 mm Allen wrench to remove four (4) screws on the seat, then remove the seat.

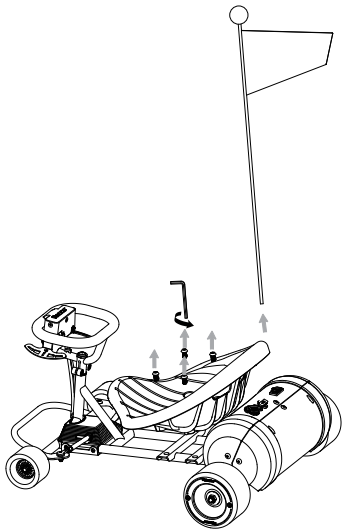
**Step 2**

Use a Phillips screwdriver to remove five (5) screws on the battery rear cover.

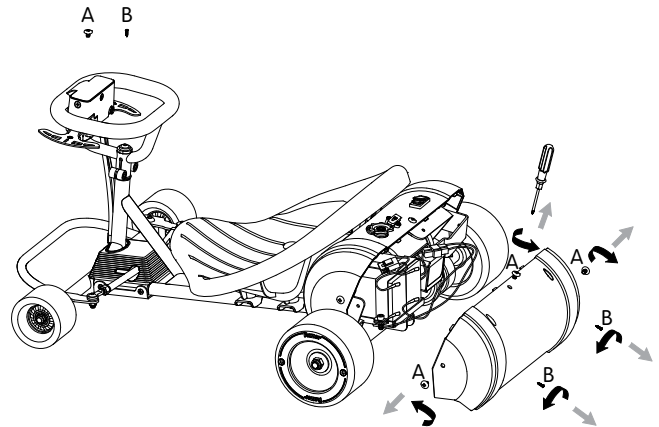

Step 3

Use a Phillips screwdriver to remove three (3) screws on the battery front cover. Then remove the battery front cover after unplugging all plugs.

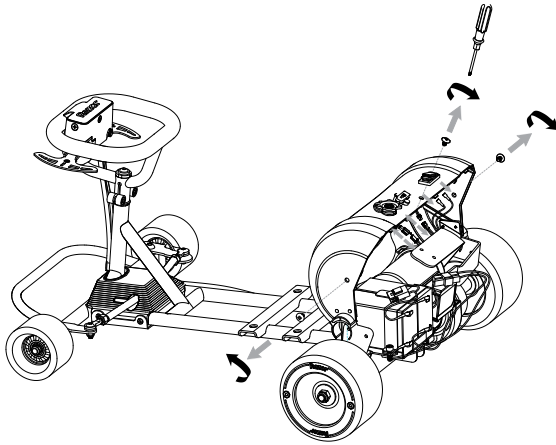

Step 4

Using a Phillips screwdriver, remove the screws from the chain cover and remove the cover.

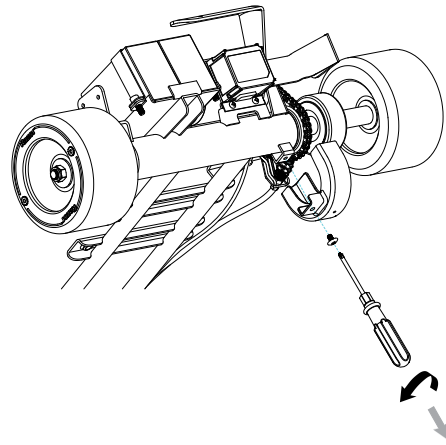

Step 5

Using two (2) 17 mm Socket wrenches, loosen and remove the lock nuts from the rear wheels.

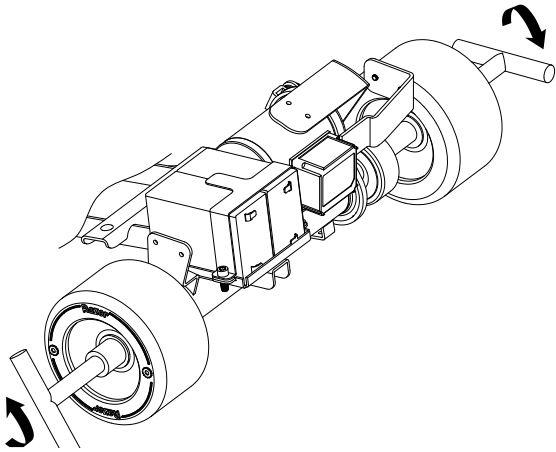

Step 6

Remove the wheels and hardware from the axle and set aside.

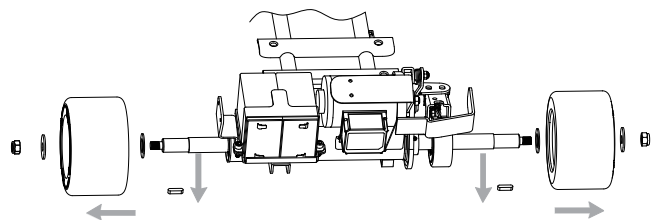

Step 7

Use a 5 mm Allen wrench and a 10 mm open-end wrench to remove two (2) bolts and lock nuts from the brake drum.

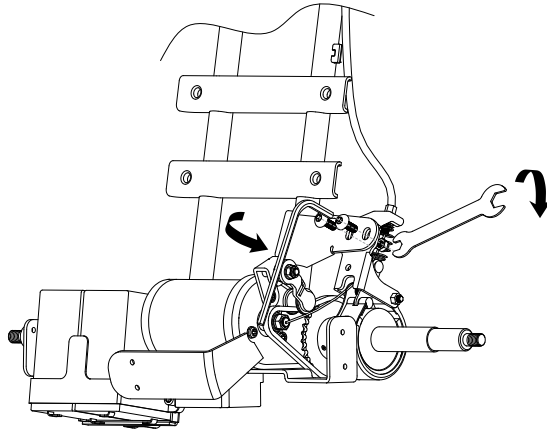

Step 8

Use a 3 mm Allen wrench to remove the set screw on the brake hub. Slide the brake drum and brake hub off from the axle.

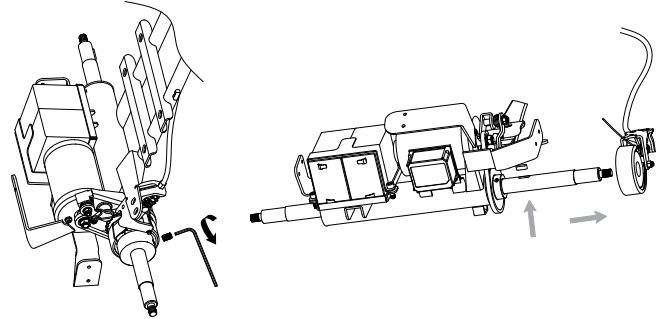

Step 9

Using long needle pliers, remove the master link from the chain and remove the chain.

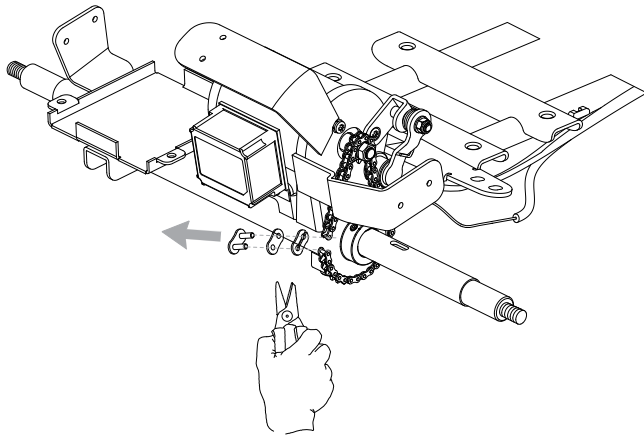

Step 10

Use a 3 mm Allen wrench to remove the set screw from the sprocket and slide it out from the axle.

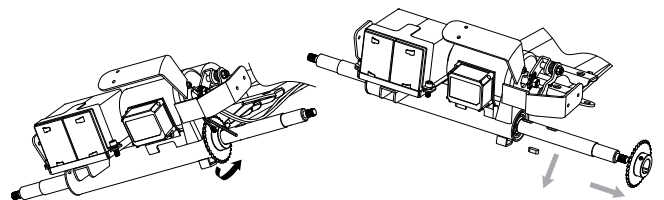

Step 11

Use C clip pliers to take off the snap rings on both sides.

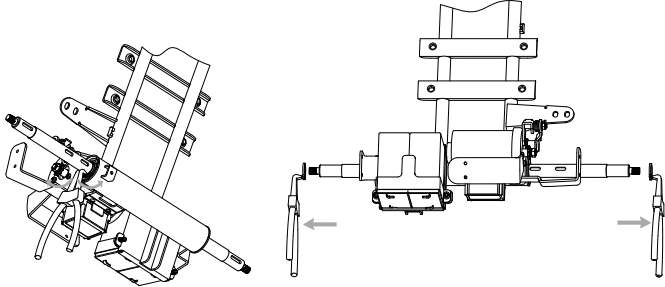

Step 12

Remove the rear axle from the frame.

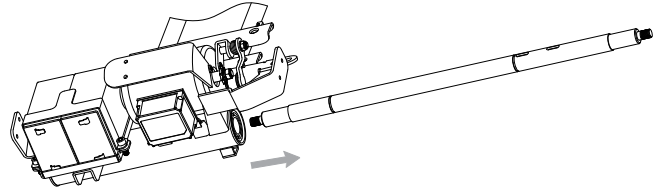

Step 13

To install a new rear axle, reverse steps 1 through 12.

ATTENTION: Charge battery 8 hours before using.

