



DUNE BUGGY™



OWNER'S MANUAL

Read and understand this entire manual before allowing child to use this product! For assistance contact Razor. DO NOT RETURN TO STORE.

NOTE: Manual illustrations are for demonstration purposes only. Illustrations may not reflect exact appearance of actual product. Specifications subject to change without notice.

Please have your product along with the 19 character product I.D. code with you before contacting Razor for warranty assistance and/or replacement parts.

Product I.D. Code: _____ - _____ - _____

CONTENTS

Safety Warnings	1	Repair and Maintenance.....	6
Before You Begin.....	2	Troubleshooting Guide	7
Set-Up	3	Dune Buggy Parts.....	8
Pre-Ride Checklist.....	5	Warranty and Contact Information	10

SAFETY WARNINGS

⚠ WARNING: Riding an electric product does present potential risks and caution is required. Like any riding product, the Dune Buggy has inherent hazards associated with its use (for example, falling off or riding it into a hazardous situation). Like any riding product, the Dune Buggy can and is intended to move and it is therefore, of course, possible to lose control or otherwise get into dangerous situations. Both children and adults responsible for supervising them must recognize that if such things occur, a rider can be seriously injured or die, even when using safety equipment and other precautions. **RIDE AT YOUR OWN RISK AND USE COMMON SENSE.**

⚠ WARNING: PARENTAL AND ADULT RESPONSIBILITY AND SUPERVISION IS NECESSARY: Because products, like the Dune Buggy, can and do present potential hazards plainly associated with their use, it is well recognized THE NEED FOR EXERCISE OF PARENTAL RESPONSIBILITY IN SELECTING RIDING PRODUCTS APPROPRIATE TO THE AGE OF A CHILD, OR PARENTAL SUPERVISION IN SITUATIONS IN WHICH CHILDREN OF VARIOUS AGES MAY HAVE ACCESS TO THE SAME RIDING PRODUCTS, IS IMPORTANT. Not every product is appropriate for every age or size of child, and different age recommendations are found within this category of product which are intended to reflect the nature of the hazards and the expected mental or physical ability, or both, of a child to cope with the hazards.

The recommended minimum rider age is eight (8) and older. Any rider unable to fit comfortably on the product should not attempt to ride it. A parent's decision to allow his or her child to ride this product should be based on the child's maturity, skill and ability to follow rules.

Keep this product away from small children and remember that it is intended for use only by persons who are, at a minimum, completely comfortable and competent while operating the product.

Persons with any mental or physical conditions that may make them susceptible to injury, impair their physical dexterity or mental capabilities to recognize, understand, and follow safety instructions and to be able to understand the hazards inherent in product use, should not use or be permitted to use products inappropriate for their abilities. Persons with heart conditions, head, back or neck ailments (or prior surgeries to these areas of the body), or pregnant women, should be cautioned not to operate such products.

DO NOT EXCEED THE WEIGHT LIMIT OF 120 lb (54 kg). Rider weight does not necessarily mean a person's size is appropriate to fit or maintain control of the Dune Buggy.

CHECK AND MAINTAIN PRODUCT CONDITIONS

Before use, check to confirm that any and all chain guards or other covers are in place and in serviceable condition. Check that the brake is functioning properly, and that tires are inflated properly and have sufficient tread remaining. The product should be maintained and repaired in accordance with the manufacturer's specifications, using only the manufacturer's authorized replacement parts, and should not be modified from the manufacturer's original design and configuration.

ACCEPTABLE RIDING PRACTICES AND CONDITIONS

Always check and obey any local laws or regulations which may affect the locations where the Dune Buggy may be used.

Ride defensively. Watch out for potential obstacles that could catch your wheel or force you to swerve suddenly or lose control. Be careful to avoid pedestrians, skaters, skateboards, scooters, bikes, children or animals who may enter your path, and respect the rights and property of others.

The Dune Buggy is meant to be used on private property and on closed courses, and not on public streets or sidewalks. Do not ride your electric product in any areas where pedestrian or vehicle traffic is present.

Do not activate the throttle unless you are on the product and in a safe, outdoor environment suitable for riding.

This product was manufactured for performance and durability but is not impervious to damage. Jumping or other aggressive riding can over-stress and damage any product, including the Dune Buggy, and the rider assumes all risks associated with high-stress activity.

Be careful and know your limitations. Risk of injury increases as the degree of riding difficulty increases. The rider assumes all risk associated with aggressive riding activities.

Maintain a hold on the steering wheel at all times.

Never carry passengers or allow more than one person at a time to ride the electric product.

Never use near steps or swimming pools.

Do not allow hands, feet, hair, body parts, clothing, or similar articles to come in contact with moving parts of the product, wheels or drive train, chain while the motor is running.

Do not touch the brake or electric motor on your electric product when in use as they can become very hot.

Never use headphones, a cell phone or text when riding.

Never hitch a ride with another vehicle.

Do not ride the Dune Buggy in wet or icy weather and never immerse the electric product in water, as the electrical and drive components could get damaged by water or possibly create other unsafe conditions.

Wet, slick, bumpy, uneven or rough surfaces may increase risks. Do not ride the electric product in mud, ice, puddles or water. Avoid excessive speeds that can be associated with downhill rides. Never risk damaging surfaces such as carpet or flooring by use of an electric product indoors.

Do not ride at night or when visibility is limited.

PROPER RIDING ATTIRE

Always wear proper protective equipment such as an approved safety helmet (with chin strap securely buckled). A helmet may be legally required by local law or regulation in your area. Elbow pads and kneepads, a long-sleeved shirt, long pants and gloves are recommended. Always wear athletic shoes (lace-up shoes with rubber soles), never drive barefooted or in sandals, and keep shoelaces tied and out of the way of the wheels, motor and drive system.

USING THE CHARGER

The charger supplied with the electric product should be regularly examined for damage to the cord, plug, enclosure and other parts. In the event of such damage, the product must not be charged until the charger has been repaired or replaced.

Use only with the recommended charger.

Use caution when charging.

The charger is not a toy. Charger should be operated by an adult.

Do not operate charger near flammable materials.

Unplug charger and disconnect from product when not in use.

Always disconnect from the charger prior to wiping down and cleaning your product with a damp cloth.

FAILURE TO USE COMMON SENSE AND HEED THE ABOVE WARNINGS FURTHER INCREASES RISK OF SERIOUS INJURY. USE AT YOUR OWN RISK AND WITH APPROPRIATE AND SERIOUS ATTENTION TO SAFE OPERATION. USE CAUTION.

BEFORE YOU BEGIN

Remove contents from box. Remove the separators that protect the components from damage during shipping. Inspect the contents of the box for scratches in the paint, dents or kinked cables that may have occurred during shipping. Because the Dune Buggy was 99 percent assembled and packed at the factory, there should not be any problems, even if the box has a few scars or dents.

MAKE SURE POWER SWITCH IS TURNED "OFF" BEFORE CONDUCTING ANY MAINTENANCE PROCEDURES.

Estimated Set-Up Time

Allow up to 12 hours for initial charge (see page 4 for charging information).

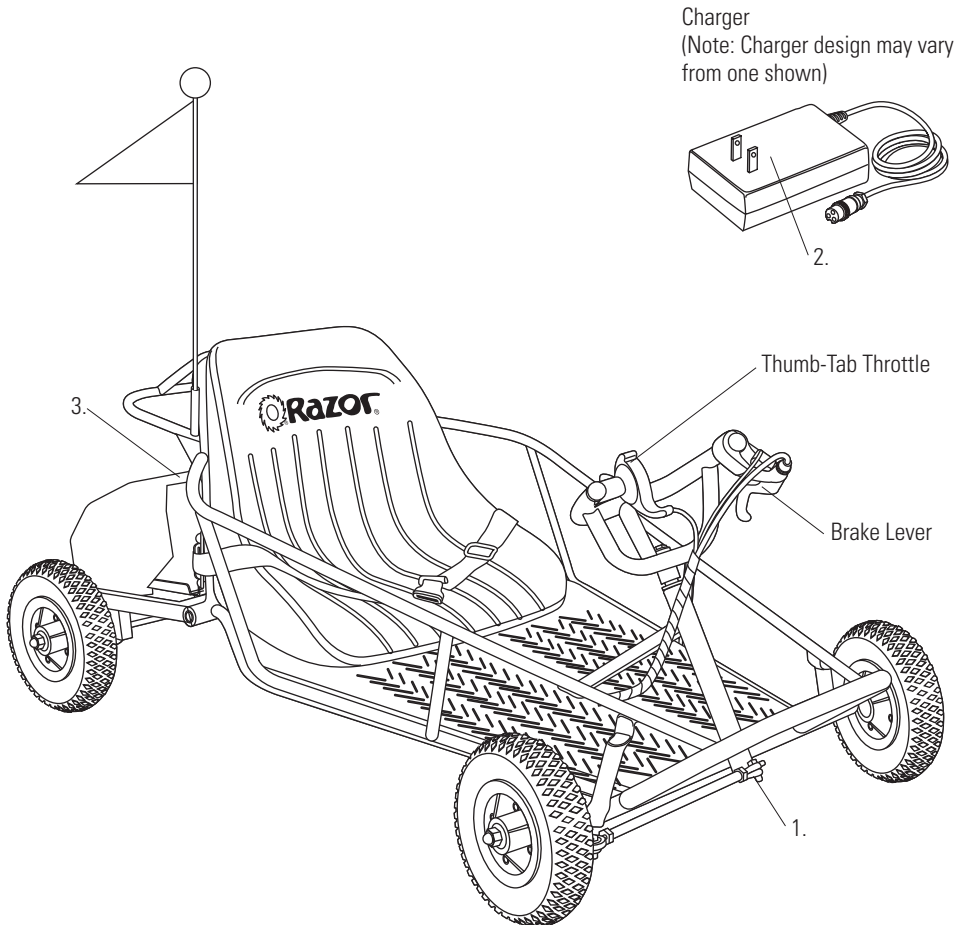

WARNING:
DO NOT USE NON-RAZOR PARTS WITH YOUR DUNE BUGGY. The Dune Buggy has been built to certain Razor design specifications. The original equipment supplied at the time of sale was selected on the basis of its compatibility with the frame and all other parts. Certain aftermarket components may not be compatible. Use of non-Razor parts will void the warranty.

WARNING:
Turn power switch **OFF** before conducting any assembly or maintenance procedures.

Product ID Locations:
(See locations to the left)

1. Frame (underneath Steering Wheel)
2. Charger
3. Battery Cover (next to Power Switch)
4. Box (not shown)

NOTICE: The lap/shoulder belt arrangement supplied with the Dune Buggy is not intended for use in larger, faster vehicles and is for "play" use only. It is not an ASTM-approved safety belt system and is not intended to function as an approved lap/shoulder/seat restraining device.

Plastic Bag Contents:

- Charger
- Owner's Manual

Need Help? Visit our website for replacement parts, product support, a list of authorized service centers in the US and customer service contact information at www.razor.com. Please have the product I.D. code (located on the white label of your product) available for better assistance. Additional Customer Service contact information is listed at the back of this manual.

SET UP

□ Attaching the Flag

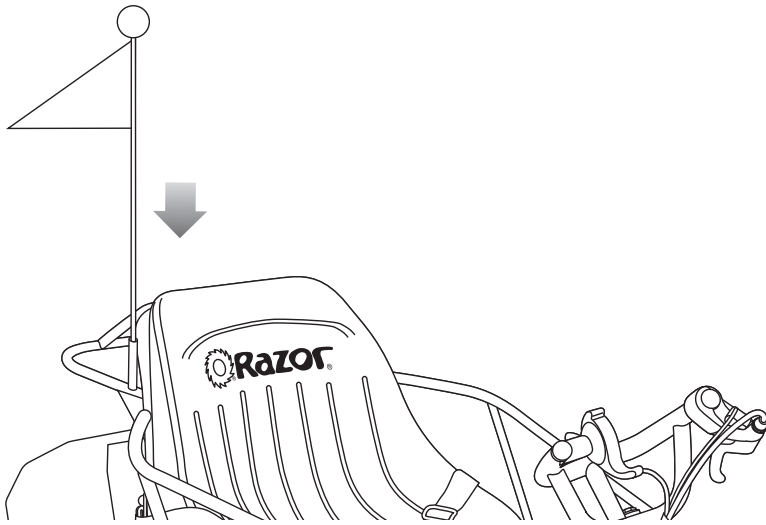

1 Insert flag into tube hole located on the top left side of frame.

□ Inflating the Tires

Tires are inflated when shipped, but they invariably lose some pressure between the point of manufacturing and your purchase. **Inflate the tires to the correct PSI before first time use.**

Lower air pressure can result in a shorter ride time.
Periodically check both tires. Reinflate when needed.

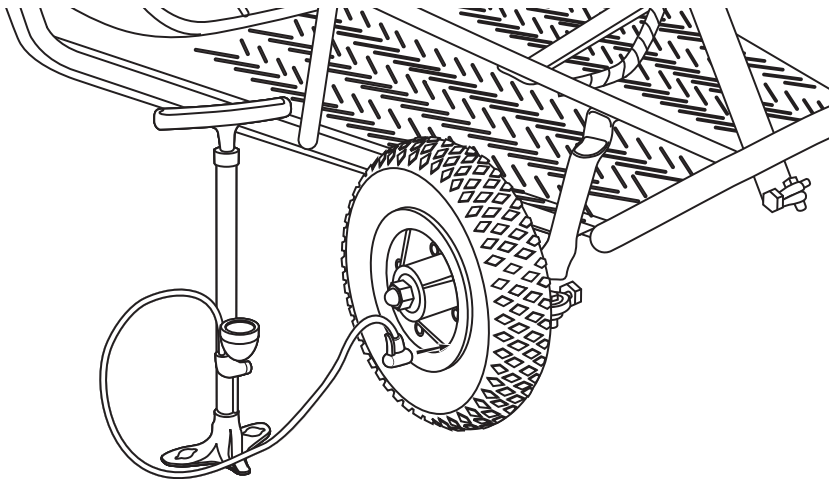

Using a bicycle style tire pump equipped for a Schrader-type valve, inflate the tires with a pressure gauge to the PSI indicated on the sidewall of the tires.

⚠ WARNING:

Do not use the Dune Buggy for the first time until you have inflated the tires to the correct PSI. Failure to do so may damage your electric product and void your warranty.

⚠ WARNING:

Do not over inflate, as this could damage the tire or wheel.

Note: The pressurized air supplies found at gasoline stations are designed to inflate high-volume automobile tires. If you decide to use such an air supply to inflate your tires, first make sure the pressure gauge is working, then use very short bursts to inflate to the correct PSI. If you inadvertently over inflate the tire, release the excess pressure immediately.

CHARGING THE BATTERY

Your Dune Buggy may not have a fully charged battery, therefore you must charge the battery prior to use.

- Initial charge time: 12 hours.
 - Recharge time: up to 12 hours, even if the light turns green. Recommended maximum charging time is 24 hours.
 - Always charge the battery immediately after riding.
 - Fully charge battery before storing for extended periods of time.
 - Unplug charger from the wall outlet when not in use.
 - Failure to recharge battery periodically may result in a battery that will not accept a charge.
 - Make sure the Dune Buggy's power switch is turned **OFF** when unit is not in use. If the power switch is left on for an extended period of time, the battery may reach a stage at which it will no longer hold a charge.
- To ensure long battery life, never store the product in freezing or below freezing temperatures! Freezing will permanently damage the battery.
 - Run time: Up to 40 minutes of continuous ride time. Run time may vary depending on riding conditions, rider weight, climate, and/or proper maintenance.
 - Constant stopping and starting may shorten ride time.
 - Battery life can vary depending on proper maintenance and usage of the unit.

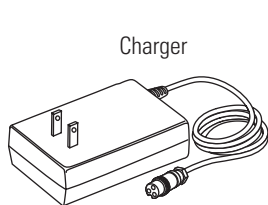

Charger

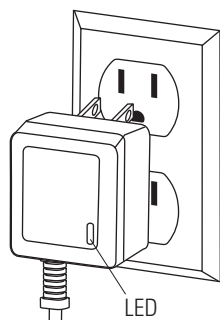

LED

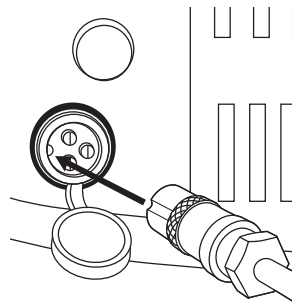

Note: Make sure power is turned **OFF** when unit is not in use. If the power switch is left on for an extended period of time, the battery may reach a stage at which it will no longer hold a charge.

1 Plug the charger plug into wall outlet. The light on the charger should be green.

Note: If green light (LED) does not turn on, try a different outlet.

2 Make sure the power switch is in the **OFF** position. Plug the charger into the charger port on the Dune Buggy. The light on the charger should turn red during charging. The light will turn green again when charging is complete.

! WARNING:

Use **ONLY** with the recommended charger. Batteries are only to be charged under adult supervision. The charger is not a toy. Always disconnect the charger before wiping down and/or cleaning the Dune Buggy with a damp cloth.

The charger supplied with the Dune Buggy should be regularly examined for damage to the cord, plug, enclosure and other parts. In the event of such damage, the Dune Buggy must not be charged until it has been repaired or replaced.

Chargers have built-in over-charge protection to prevent battery from being over-charged.

Note: If the charger gets warm during regular use, this is a normal response and is no cause for concern. If your charger does not get warm during use, it does not mean that it is not working properly.

Wall outlet - Green (Stand By)
Wall outlet and unit - Red (Charging)
Charging complete - Green (Charged)

Note: Continue charging unit even if light turns green prior to 12 hours.

! WARNING: Battery charge can deplete over time. Periodically recharge battery when not in use.

PRE-RIDE CHECKLIST



Brake

Check the brake for proper function. When you squeeze the brake lever, the brake should provide positive braking action. When you apply the brake with the speed control on, the brake cut-off switch will shut off the motor.



Tires

Periodically inspect the tires for excess wear, and regularly check the tire pressure and re-inflate as necessary. If you get a flat tire, the inner tube can be patched or a new tube can be purchased from Razor or an authorized repair center.



Frame, Fork and Handlebars

Check for cracks or broken connections. Although broken frames are rare, it is possible for an aggressive rider to run into a curb or wall and wreck, bend or break a frame. Get in the habit of inspecting the Dune Buggy before every ride.



Hardware/Loose Parts

Before every ride, check all parts, such as nuts, bolts, cables, fasteners, etc., to ensure they are secure and assembled correctly. There should not be any unusual rattles or sounds from loose parts or broken components. If the unit is damaged, do not ride.

Reference "Safety Warnings" on page 1 of this manual.



Safety Gear

Always wear proper protective gear, such as an approved safety helmet. Elbow pads and kneepads are recommended. Always wear athletic shoes (lace-up shoes with rubber soles) and keep shoelaces tied and out of the way of the wheels, motor and drive system. **NEVER RIDE BAREFOOTED OR IN SANDALS.**



Laws and Regulations

Always check and obey any local laws or regulations.



Insurance

Do not assume that your existing insurance policies necessarily provide coverage for this product's use. Check with your insurance company for information regarding insurance.

USAGE

How to Start

Position your body in the seat and place one foot on each side of the steering wheel. Fasten the lap/shoulder belt on. Turn power switch on, place both hands on the steering wheel and apply the thumb tab throttle.

Note: Keep hands on the steering wheel and both feet inside the unit when unit is in motion.

How to Stop

Release the thumb tab throttle and apply the brake lever until the unit comes to a complete stop.

REPAIR AND MAINTENANCE

Turn power switch **OFF** before conducting any maintenance procedures.

- Read the instructions
- Remove charger plug
- Turn the power switch **OFF**
- Secure the unit under repair
- Exercise caution around exposed parts
- Contact Razor customer service if unsure about any repair or maintenance

❑ Replacing the Fuse

***BATTERY COVER NEEDS TO BE REMOVED TO HAVE ACCESS TO BATTERY.**

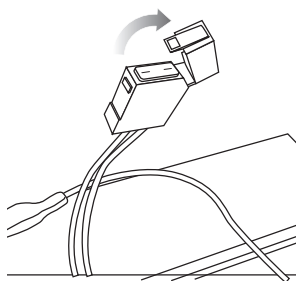

1 Open fuse box located on the battery.

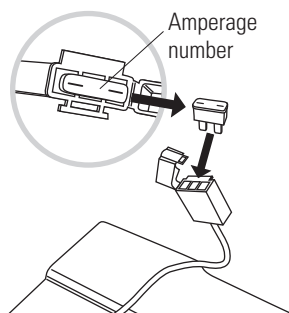

2 Remove fuse and replace with a new one of equal amperage.
Note: Amperage is located on top of fuse. Fuse must be replaced with one of equal amperage.

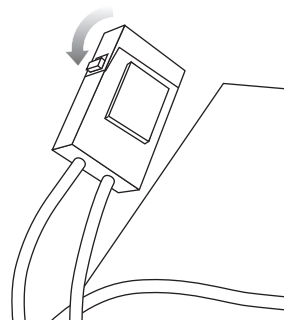

3 Close the fuse box.

❑ Battery Care and Disposal

Do not store in freezing or below freezing temperatures. To properly maintain your battery and ensure maximum battery life, carefully read the "Charging the Battery" section on page 4 of this owner's manual.



CONTAINS SEALED LEAD-ACID BATTERIES. BATTERIES MUST BE RECYCLED.

Disposal: Your Razor product uses sealed lead-acid batteries which must be recycled or disposed of in an environmentally safe manner. Do not dispose of a lead-acid battery in a fire. The battery may explode or leak. Do not dispose of a lead-acid battery in your regular household trash. The incineration, land filling or mixing of sealed lead-acid batteries with household trash is prohibited by law in most areas. Return exhausted batteries to a federal or state approved lead-acid battery recycler or a local seller of automotive batteries. If you live in Florida or Minnesota, it is prohibited by law to throw away lead-acid batteries in the municipal waste stream.

❑ Charger

The charger supplied with the Dune Buggy should be regularly examined for damage to the cord, plug, enclosure and other parts, and in the event of such damage, the product must not be charged until it has been repaired or replaced.

Use **ONLY** with the recommended charger.

❑ Wheels

Wheels and drive system are subject to normal wear and tear. It is the responsibility of the user to periodically inspect wheels for excess wear and adjust and replace drive train components as required.

❑ Replacement Parts

The most frequently requested replacement parts are available for purchase at some Razor retail partners. For the complete selection of replacement parts visit www.razor.com.

❑ Repair Centers

For a list of authorized Razor repair centers:

- Check online at www.razor.com.
- Additional Customer Service contact information is listed on the back of this manual.

! WARNING:

To prevent shock, make sure power is in the "**OFF**" position and charger is not plugged into unit while conducting any maintenance procedures.



In the US and Canada only:

For more information regarding recycling of rechargeable batteries, call toll free 1-800-822-8837, or visit <http://www.call2recycle.org>

! WARNING:

If a battery leak develops, avoid contact with leaking acid and place the damaged battery in a plastic bag. Refer to the disposal instructions at left. If acid comes into contact with skin or eyes, flush with cool water for at least 15 minutes and contact a physician.

! WARNING:

Battery posts, terminals and related accessories contain lead and lead compounds. **Wash your hands after handling.**

Need Help? Visit our website for replacement parts, product support, a list of authorized service centers in the US and customer service contact information at www.razor.com. Please have the product I.D. code (located on the white label of your product) available for better assistance. Additional Customer Service contact information is listed at the back of this manual.

TROUBLESHOOTING GUIDE

*Unit(s) should be turned off and fully charged prior to doing any Troubleshooting
NOTE: All troubleshooting steps should be performed by an adult only

Problem	Possible Cause	Solution
Product does not run.	Product is rolling backwards.	Throttle will not engage if the product is rolling backwards. Come to a complete stop and then activate the throttle.
	Undercharged battery.	Charge the battery. A new battery should have been charged for at least 12 hours before using the product for the first time and up to 12 hours after each subsequent use. Check all connectors. Make sure the charger connector is tightly plugged into the charging port and that the charger is plugged into a functioning wall outlet.
	Charger is not working.	Contact Razor Customer Service to get replacement charger.
Product was running but suddenly stopped.	Loose wires or connectors.	Check all wires and connectors to make sure they are tight.
	Burned-out fuse.	The fuse will burn out and automatically shut off the power if the motor is overloaded. An excessive overload, such as too heavy a rider or too steep a hill, could cause the motor to overheat. Refer to page 6 - "Replacing the Fuse". Correct the conditions that caused the fuse to burn out and avoid repeatedly burning out fuse. Contact your local Razor authorized service center for diagnosis and repair. Contact Razor customer service or visit www.razor.com
Short run time.	Undercharged battery.	Charge the battery. A new battery should have been charged for at least 12 hours before using the product for the first time and up to 12 hours after each subsequent use.
	Battery is old and will not accept full charge.	Even with proper care, a rechargeable battery does not last forever. Average battery life depends on product use and conditions. Replace only with a Razor replacement battery.
Product runs sluggishly.	Riding conditions are too stressful.	Use only on solid, flat, clean and dry surfaces, such as pavement or level ground.
	Tires are not properly inflated.	Check tire pressure.
	Product is overloaded.	Make sure you do not overload the product by allowing more than one rider at one time, exceeding the maximum weight limit, going up too steep a hill or towing objects behind the product.
Sometimes the product doesn't run, but other times it does.	Loose wires or connectors.	Check all wires and connectors to make sure they are tight.
	Motor or electrical switch damage.	Contact your local Razor authorized service center for diagnosis and repair. Contact Razor customer service or visit www.razor.com .
Charger gets warm during use.	Normal response to charger use.	No action required. This is normal for some chargers and is no cause for concern. If your charger does not get warm during use, it does not mean that it is not working properly.
Product makes loud noises or grinding sounds.	Chain is too dry.	Apply a lubricant such as 3 in 1™ or Tri-Flow™ to the chain.

For more troubleshooting tips, a list of available replacement parts or to locate an authorized Service Center in your area, visit our website at www.razor.com or call toll free +1 866 467 2967 to speak to a live Customer Service Representative

DUNE BUGGY PARTS

Keep your Dune Buggy running for years with genuine Razor parts. Visit our website or e-mail us for more information on spare part availability. (Specifications subject to change without notice.)

- | | | |
|---------------------------|--|---------------------------------|
| 1. Front Wheels | 10. Control Module | 19. Chain (Motor) |
| 2. Steering Assembly | 11. Motor (24V/250W) | 20. Chain (Rear Axle) |
| 3. Footrest | 12. Battery (2-12V/7Ah) With 30 Amp Fuse | 21. Chain Tensioner |
| 4. Platform (Left/Right) | 13. Rear Wheels | 22. Battery Cover (Upper/Lower) |
| 5. Steering Wheel | 14. Rear Axle | 23. Charger Port |
| 6. Thumb-Tab Throttle | 15. Upper/ Lower Clamp (Rear Axle) | 24. On/ Off Switch |
| 7. Brake Lever with Cable | 16. Disc Brake | 25. Flag |
| 8. Shock Absorber | 17. Brake Caliper | |
| 9. Seat | 18. Rear Axle Sprocket | |

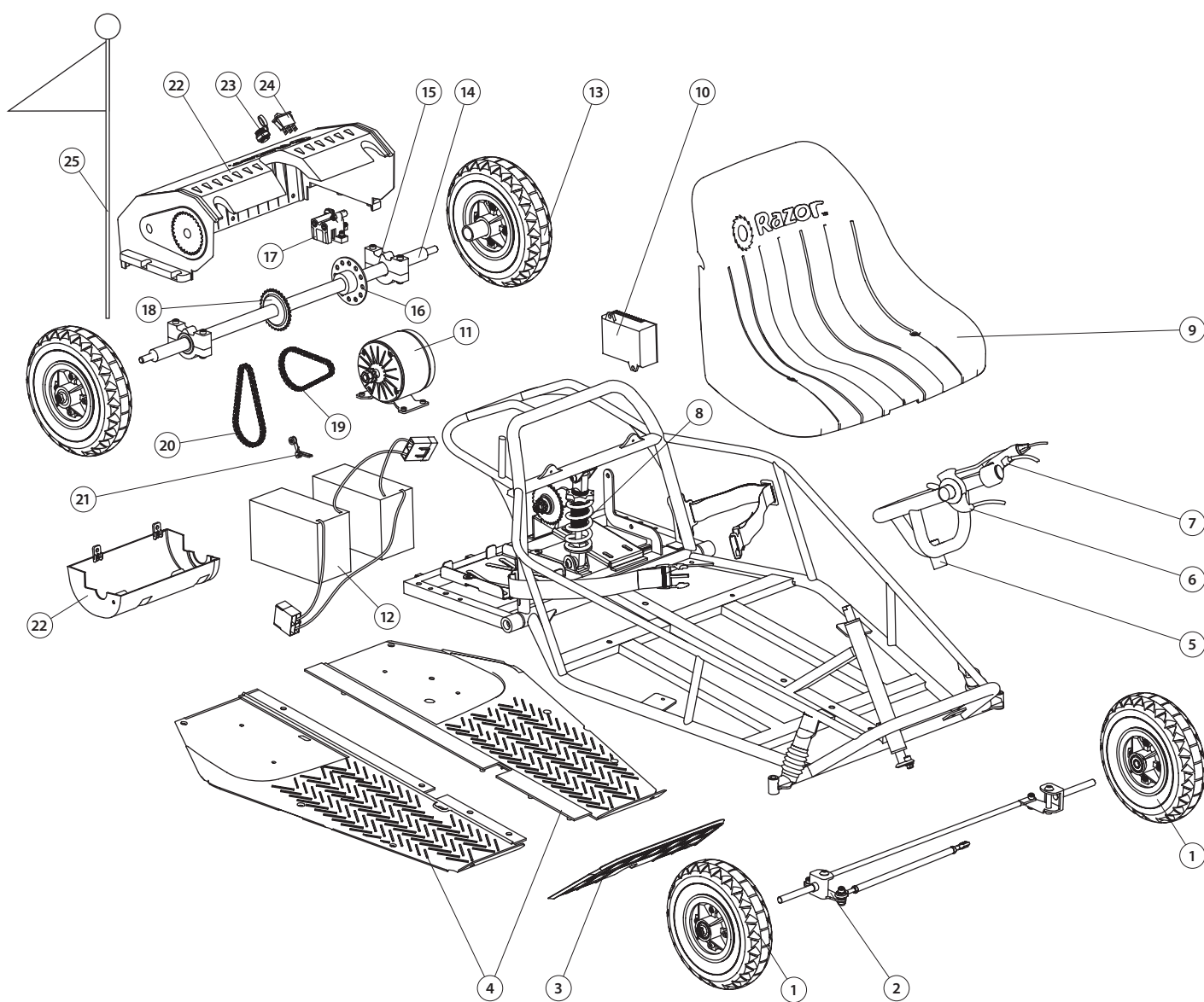

**NOTICE: INSURANCE
YOUR INSURANCE POLICIES MAY NOT PROVIDE COVERAGE FOR
ACCIDENTS INVOLVING THE USE OF THIS ELECTRIC RIDE-ON
PRODUCT. TO DETERMINE IF COVERAGE IS PROVIDED, YOU
SHOULD CONTACT YOUR INSURANCE COMPANY OR AGENT.**

FCC COMPLIANCE

This device complies with Part 15 of the FCC Rules. Operation is subject to the following two conditions: (1) This device may not cause harmful interference, and (2) this device must accept any interference received, including interference that may cause undesired operation.

Note: This equipment has been tested and found to comply with the limits for a Class B digital device, pursuant to part 15 of the FCC Rules. These limits are designed to provide reasonable protection against harmful interference in a residential installation. This equipment generates, uses and can radiate radio frequency energy and, if not installed and used in accordance with the instructions, may cause harmful interference to radio communications. However, there is no guarantee that interference will not occur in a particular installation. If this equipment does cause harmful interference to radio or television reception, which can be determined by turning the equipment off and on, the user is encouraged to try to correct the interference by one or more of the following measures:

- Reorient or relocate the receiving antenna.
- Increase the separation between the equipment and receiver.
- Connect the equipment into an outlet on a circuit different from that to which the receiver is connected.
- Consult the dealer or an experienced radio/TV technician for help.

! WARNING: Changes or modifications to this unit not expressly approved by Razor USA, could void the user's authority to operate the equipment.

WARRANTY

Razor Limited Warranty

The manufacturer warrants this product to be free of manufacturing defects for a period of 90 days from date of purchase. This Limited Warranty does not cover normal wear and tear, tires, tubes or cables, or any damage, failure or loss caused by improper assembly, maintenance, storage or use of the Razor Dune Buggy.

This Limited Warranty will be void if the product is ever:

- used in a manner other than for recreation or transportation;
- modified in any way;
- rented.

The manufacturer is not liable for incidental or consequential loss or damage due directly or indirectly to the use of this product.

Razor does not offer an extended warranty. If you have purchased an extended warranty, it must be honored by the store at which it was purchased.

For your records, save your original sales receipt with this manual and write the serial number below.

CUSTOMER SERVICE CONTACT INFORMATION

Need Help? Visit our website for replacement parts, product support, a list of authorized service centers in the US and customer service contact information at www.razor.com. Please have the product I.D. code (located on the white label of your product) available for better assistance. Additional Customer Service contact information is listed below:

AMERICAS

Razor USA LLC
P.O. Box 3610
Cerritos, CA 90703
USA

+1 866 467 2967
Monday - Friday
8:00 AM - 5:00 PM Pacific Time
customersupport@razorusa.com

EUROPE, MIDDLE EAST, AFRICA

Razor USA LLC (Europe)
Handelsweg 2
2742 RD Waddinxveen
Netherlands

+44 (0) 120 267 2702
info@razoreu.com

ASIA

Razor USA LLC (Asia)
P.O. Box 3610
Cerritos, CA 90703
USA

+81 50 7579 6622
info@razor-asia.com

UNITED KINGDOM AND IRELAND

Razor USA LLC (UK)
Unit 20
Hartnoll Business Centre
Post Hill, Tiverton
Devon EX16 4NG
UK

+44 (0) 120 267 2702
info@razoreu.com

AUSTRALIA AND NEW ZEALAND

Razor USA LLC
P.O. Box 4280
Auburn South
VIC 3122
Australia

+1 800 954 354 (AU)
+0 800 003 221 (NZ)
info@razoranz.com

IMPORTED IN JAPAN BY B-PLUS ASIA CORP.

Razor USA LLC
THE RIZSTIK COMPANY
Kurokawa 3-1, Asaoku,
Kawasaki, Kanagawa
215-0035 JAPAN

+81 (0) 44 328 9057 Tel
+81 (0) 44 328 9067 Fax
info@razor-asia.com

Printed in China for Razor USA LLC.

Copyright © 2003-2021 Razor USA, LLC. All rights reserved. Razor® and the Razor logo design are among the registered trademarks of Razor USA LLC in the United States and/or select foreign countries. Dune Buggy logo design is a trademark of Razor USA LLC.