



A-TYPE, S-TYPE, T-TYPE & CRUISER SCOOTERS



OWNER'S MANUAL

**Read and understand this entire manual before allowing child to use this product! For assistance contact Razor.
DO NOT RETURN TO STORE.**

**NOTE: Manual illustrations are for demonstration purposes only.
Illustrations may not reflect exact appearance of actual product.
Specifications subject to change without notice.**

**Please have your product along with the 22 character product I.D. code with you
before contacting Razor for warranty assistance and/or replacement parts.**

Product I.D. Code: _____ - _____ - _____

CONTENTS

Safety Warnings.....	1	Pre-Ride Checklist and Usage.....	5
Before You Begin.....	2	Repair and Maintenance.....	6
Assembly and Set-Up.....	3-4	Warranty and Contact Information	7

SAFETY WARNINGS

⚠ AN IMPORTANT MESSAGE TO PARENTS: This manual contains important information. For your child’s safety, it is your responsibility to review this information with your child and make sure that your child understands all warnings, cautions, instructions and safety topics. All children and preteens should ride with adult guidance at all times. Razor USA recommends that you periodically review and reinforce the information in this manual with younger riders, and that you are required to inspect and maintain your child’s scooter to ensure their safety.

⚠ GENERAL WARNING: Scooter riding can be a hazardous activity. Scooters can, and are intended to move and it is therefore possible to get into dangerous situations and/or lose control and/or fall. If such things occur you can be seriously injured or die. **LIKE ANY OTHER MOVING PRODUCT, USING A SCOOTER CAN BE A DANGEROUS ACTIVITY AND MAY RESULT IN INJURY OR DEATH EVEN WHEN USED WITH PROPER SAFETY PRECAUTIONS. USE AT YOUR OWN RISK AND USE COMMON SENSE.**

This manual contains many warnings and cautions concerning the consequences of failing to maintain, inspect or properly use your scooter. Because any incident can result in serious injury or even death, we do not repeat the warning of potential serious injury or death each time such a possibility is mentioned.

- Kick scooters are generally not recommended for children under age five (5). A4 scooters are for children ages six (6) and above. Children under age eight (8) should ride with adult supervision at all times.
- Do not exceed weight limit indicated on the scooter package.

S Kick Scooter	110 lb (50 kg)
T Kick Scooter	110 lb (50 kg)
A Kick Scooter	143 lb (65 kg)
A2 Kick Scooter	143 lb (65 kg)
A3 Kick Scooter	143 lb (65 kg)
A4 Kick Scooter	220 lb (100 kg)
Cruiser Scooter	143 lb (65 kg)
Malibu Beach Scooter	174 lb (79 kg)

- Rider weight does not necessarily mean a child’s size is appropriate to fit or maintain control of the scooter.
- A parent’s decision to allow his or her child to ride this product should be based on the child’s maturity, skill and ability to follow rules.
- Always wear safety equipment, such as helmet, knee pads and elbow pads. Always wear a helmet when riding your scooter and keep the chinstrap securely buckled.
- Always wear closed toe shoes.
- Ride on smooth, paved surfaces without loose debris, such as rocks or gravel, and away from motor vehicles.
- Avoid sharp bumps, drainage grates, and sudden surface changes as scooter may suddenly stop.
- Avoid streets and surfaces with water, mud, ice, sand, gravel, dirt, leaves and other debris. Wet weather impairs traction, braking, and visibility.
- Do not ride at night or when visibility is impaired.
- Brake will get hot from continuous use. Do not touch after braking.
- Avoid excessive speed associated with downhill rides.

- Adults must assist children in the initial assembly and/or adjustment procedures to fold/unfold scooter, and adjust handlebar and steering to height.
- Obey all local traffic and scooting laws and regulations.
- Watch out for pedestrians.

ACCEPTABLE RIDING PRACTICES AND CONDITIONS

Direct parental supervision is required. Scooters are meant to be used only in controlled environments free of potential traffic hazards and not on public streets. Do not allow your child to ride a scooter in any areas where vehicle traffic is present. Child must maintain a hold on the handlebars at all times. Never allow more than one child at a time to ride a scooter. Never use near steps, sloped driveways, hills, roadways, alleys or swimming pool areas. Keep fingers and other body parts away from the product when folding or unfolding (select models). Adults must not allow children to assist in assembling and/or folding or unfolding the scooter.

Do not ride a scooter in wet weather. Scooters are intended for use on solid, flat, clean and dry surfaces, such as pavement or level ground without loose debris, such as rocks or gravel. Wet, slick or uneven and rough surfaces may impair traction and contribute to possible accidents. Do not ride a scooter in mud, ice, puddles or water. Never risk damaging surfaces, such as carpet or flooring, by use of a scooter indoors.

PROPER RIDING ATTIRE

Always ensure child is wearing proper protective equipment, such as an approved safety helmet. A helmet may be legally required by local law or regulation in your area. A child should always wear shoes and keep shoelaces tied and out of the way of the wheels. Never ride barefooted or in sandals. Knee pads and elbow pads are recommended.

⚠ WARNING: ALWAYS INSPECT SCOOTER PRIOR TO RIDING. Properly inspecting and maintaining your scooter can reduce the risk of injury. Always inspect your scooter before riding and regularly maintain it. Check and secure all fasteners before every ride. Replace worn or broken parts immediately.

⚠ WARNING: CHECK LOCAL LAWS REGARDING SCOOTER USE. Check local laws and regulations to see where and how you may use your Razor scooter legally. In many states and local areas scooter riders are required BY LAW to wear a helmet. Check local laws and regulations regarding laws governing helmet use and scooter operation in your area.

FAILURE TO USE COMMON SENSE AND HEED THE ABOVE WARNINGS FURTHER INCREASES RISK OF SERIOUS INJURY. USE AT YOUR OWN RISK AND WITH APPROPRIATE AND SERIOUS ATTENTION TO SAFE OPERATION. USE CAUTION.

BEFORE YOU BEGIN

Remove contents from box. Inspect the contents of the box for scratches and/or dents that may have occurred during shipping. Because your scooter was partially or fully assembled and packed at the factory, there should not be any problems, even if the box has a few scars or dents.

⚠ WARNING:
DO NOT USE NON-RAZOR PRODUCTS WITH YOUR SCOOTER. Razor scooters have been built to certain Razor design specifications. The original equipment supplied at the time of sale was selected on the basis of its compatibility with the frame, fork and all other parts. Certain aftermarket products may not be compatible and will void the warranty.

Product ID Locations:
(See locations to the left)

1. Side of Deck Plate
2. Box - Side of UPC (Not Shown)

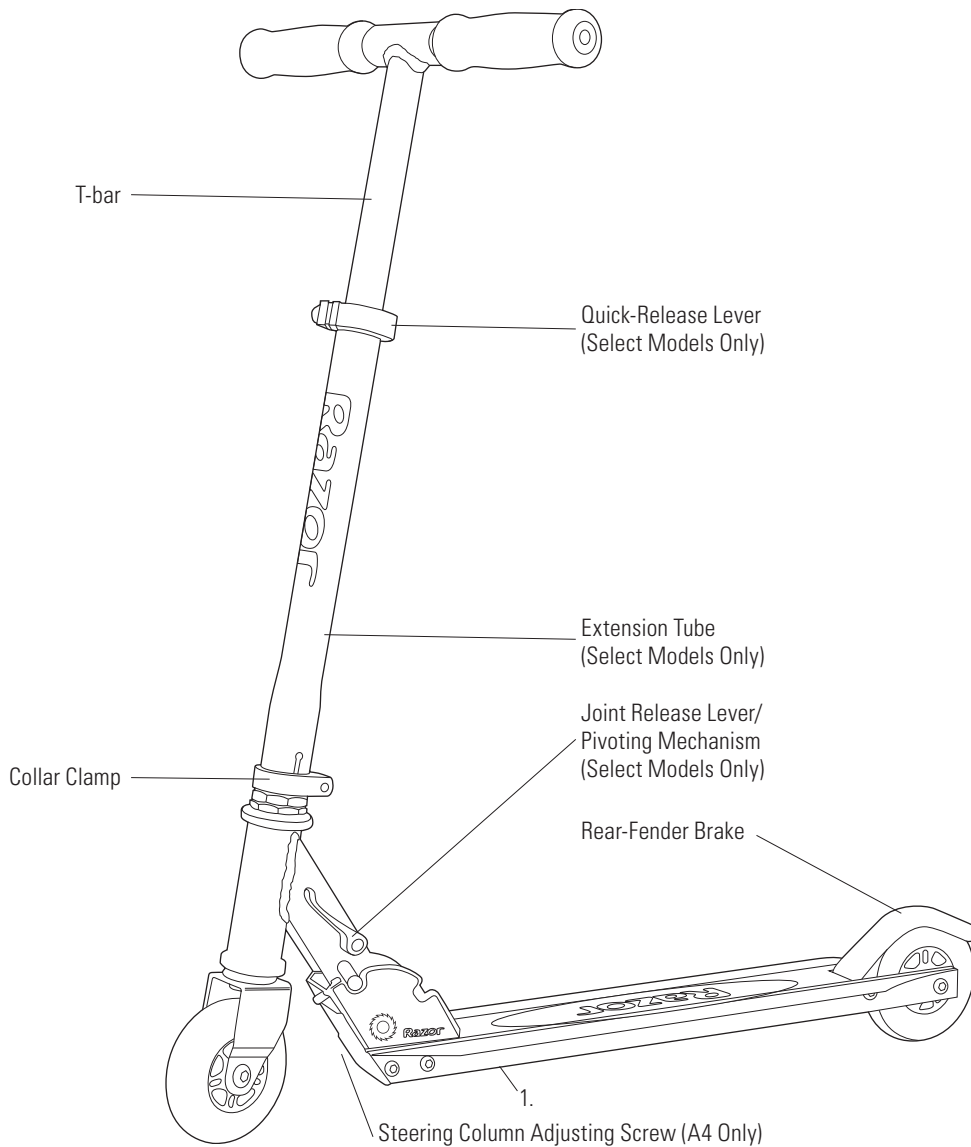

□ Required Tool

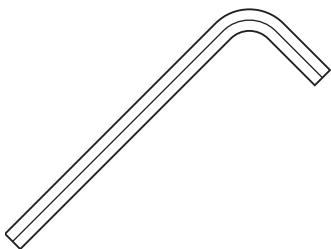

5 mm Allen Wrench
(Included with S, T and A4 Kick Scooters only)

Box Contents:

- Scooter
- Allen Wrench (Select Models Only)
- Owner's Manual

Need Help? Visit our website for replacement parts, product support, a list of authorized service centers in the US and customer service contact information at www.razor.com. Please have the product I.D. code (located on the white label of your product) available for better assistance. Additional Customer Service contact information is listed at the back of this manual.

ASSEMBLY AND SET-UP

□ Attaching the Handlebars

Required Tool: 5 mm Allen Wrench (included with select models ONLY)

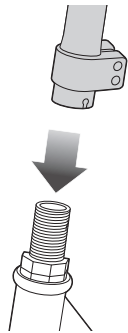

1 Loosen the collar clamp and slide it upward. Insert T-bar into the fork until it bottoms out on the headset locknut.

Note: If necessary, carefully twist the T-bar side to side while pushing downward until T-bar bottoms out on the headset locknut.

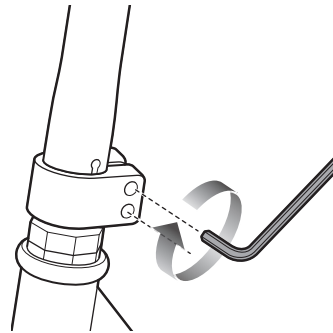

2 With the front wheel pointed straight ahead and the handlebars square to the front wheel and the Razor logo facing the front, tighten the clamp as shown. Tighten securely. On the A4, alternately tighten each bolt until securely tightened.

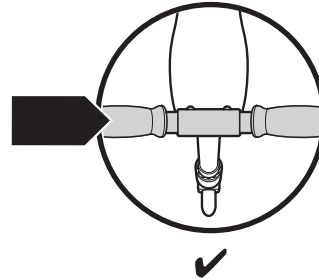
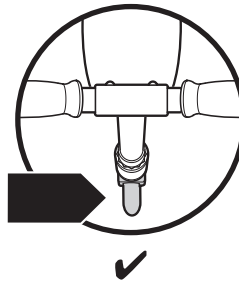

⚠ WARNING: Failure to properly install and tighten the collar clamp may cause the rider to lose control and fall. If you are having difficulty understanding these instructions, please contact Razor Customer Service for assistance.

⚠ WARNING: Do not attempt to thread the handlebar into the front fork thread. Tighten collar clamp securely.

□ Unfolding the Scooter for First Time Use

(Select models Only)

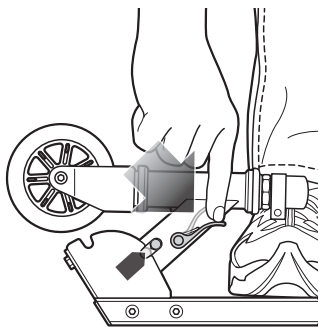

1 To release the folding mechanism, place the scooter on the ground, put one foot on the deck plate and push joint-release lever down. Raise T-bar up until it is securely locked in the upright position.

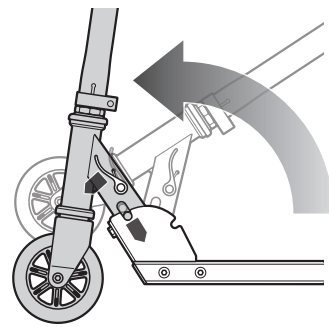

Note: The joint-release lever is spring-loaded and will automatically lock in the upright position when fully upright.

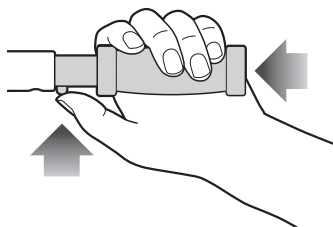

2 Insert and secure the left and right handlebars by pressing the spring-loaded buttons and inserting them into the T-bar.

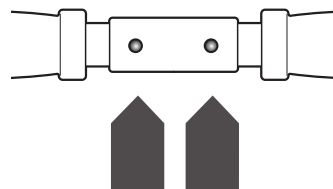

3 Make certain BOTH handlebars are properly locked onto the T-bar.

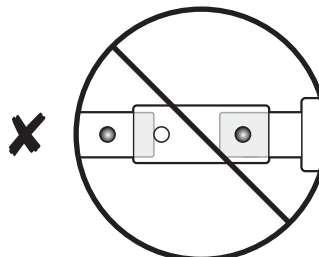
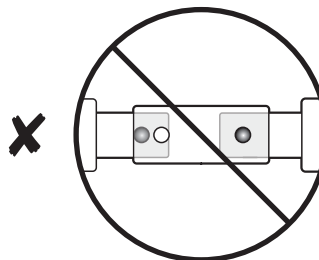

⚠ WARNING: Keep fingers clear of the pivoting mechanism when folding or unfolding the scooter. Make sure others are standing clear.

⚠ WARNING: Failure to properly engage the spring-loaded buttons may cause the handlebars to dislodge while riding and may cause you to lose control and fall. When correctly engaged the handlebars will not rotate nor will they move sideways. Note that when properly engaged, the spring-loaded buttons are clearly visible in the holes on the T-bar.

⚠ WARNING: Check hand grips and end caps regularly for wear or damage, as they are designed to aid in gripping handlebars and to provide some protection against possible impact. Replace immediately if worn, torn, damaged or missing.

ASSEMBLY AND SET-UP

□ Adjusting the Handlebar Height

(Select models Only)

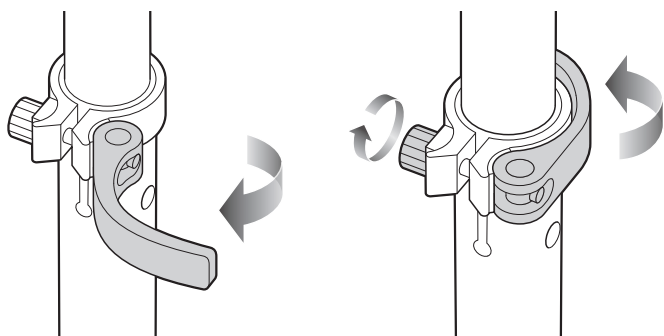

1 To adjust the height of the handlebars, open the quick-release lever and slide the T-bar to the desired position and resecure the quick-release lever to lock into place. When the T-bar is raised to the maximum height, depress the push button located directly below the quick-release lever to unlock the T-bar.

Note: The tension of the quick-release lever can be adjusted by manually tightening or loosening the Allen bolt. Be careful not to over-tighten. You should always be able to open and close the quick-release lever by hand and the T-bar should slide freely when the quick-release is open.

□ Collar Clamp

Required Tool: 5 mm Allen Wrench (included with select models ONLY)

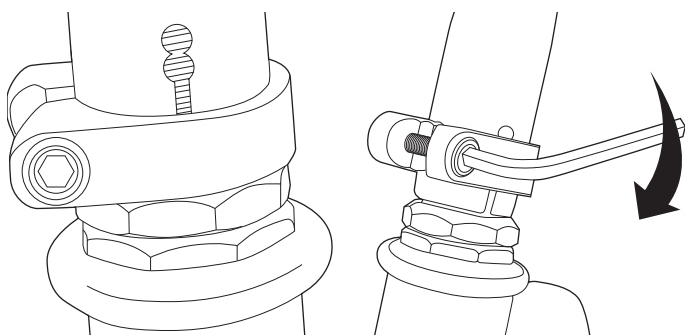

Using a 5 mm Allen wrench, check that the collar clamp bolt(s) are tightened securely. This item is tightened and quality inspected at the factory, but there is a slight chance that the effects of shipping or handling may have caused the bolt(s) to loosen.

⚠ WARNING: Failure to properly secure the quick-release lever may cause the T-bar to telescope up or down while riding and may cause you to lose control and fall.

⚠ WARNING: Failure to properly install and/or tighten the collar clamp may cause the rider to lose control and fall. If you are having difficulty understanding these instructions, please contact Razor Customer Service for assistance.

Need Help? Visit our website for replacement parts, product support, a list of authorized service centers in the US and customer service contact information at www.razor.com. Please have the product I.D. code (located on the white label of your product) available for better assistance. Additional Customer Service contact information is listed at the back of this manual.

PRE-RIDE CHECKLIST



Deck and Handlebars

Check for cracks or broken connections. Although broken decks are rare, it is possible for an aggressive rider to run into a curb or object and wreck and bend or break the deck. Get in the habit of inspecting your scooter on a regular basis.



Hardware/Loose Parts

Check and secure all fasteners before every ride. Make sure the collar clamp, quick-release lever (select models only), and handlebar spring buttons are locked properly in place before riding. There should not be any unusual rattles or sounds from loose parts or broken components. If the unit is damaged, do not ride. **Reference "Safety Warnings" on page 1 of this manual.**



Safety Gear

Always wear proper protective gear, such as an approved safety helmet. Elbow pads and kneepads are recommended. Always wear closed toe shoes (lace-up with rubber soles) and keep shoelaces tied and out of the way of the wheels. **NEVER RIDE BAREFOOTED OR IN SANDALS.**



Laws and Regulations

Always check and obey any local laws or regulations.



Be Careful!

You will see people on TV and maybe even people you know doing tricks and stunts. These are people who have been practicing on scooters for a very long time. Don't try something until you are ready. Avoid steep inclines and don't ride too fast — you can lose control and fall. Skateboard parks are not designed for scooters. Never ride in traffic or on the street and watch your surroundings for pedestrians, bikers, boarders and skaters.

Maintain a hold on the handlebars at all times.

USAGE

How to Ride

Place one foot on the baseboard, push forward with the other foot. Steer with both hands on the handlebars. For enhanced cornering, lean slightly into the direction of the turn.

How to Stop

For controlled stops, apply the brake by stepping on the rear brake. Razor recommends that you practice applying the brake at various speeds and in an open area free from obstructions before riding your scooter around others.

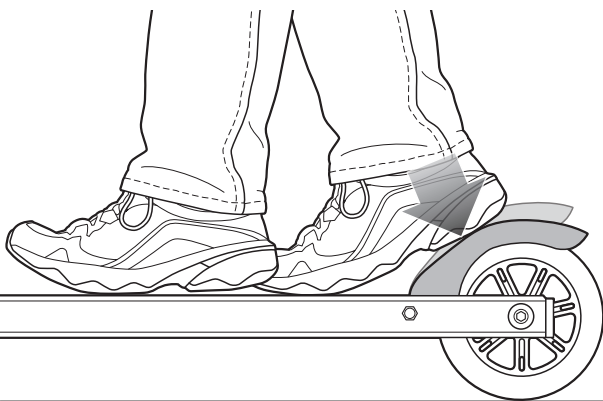

REPAIR AND MAINTENANCE

❑ Cleaning Your Scooter

Wipe with a damp cloth to remove dirt and dust. Do not use industrial cleaners or solvents as they may damage the surfaces. Do not use alcohol, alcohol-based or ammonia-based cleaners as they may damage or dissolve the plastic components or soften the decals or decal adhesive.

❑ Baseboard/Steering Column Adjusting Screw (A4 ONLY)

Required Tool: 3 mm Allen Wrench (not included)

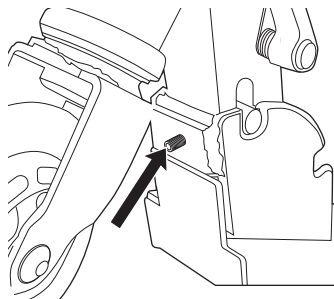

Using a 3 mm Allen wrench and with the scooter in the upright and locked position, adjust the set screw at the baseboard until there is no free-play between the baseboard and the steering column. Be careful not to over-tighten this screw as it need only be snug against the steering column. Verify the adjustment by releasing the steering column from the locked position and folding the scooter. The joint lever should not bind and the folding movement should be smooth. The spring-loaded mechanism should automatically lock and be fully seated in the upright position.

❑ Wheels and Bearings

Under normal circumstances and conditions, Razor wheels and wheel bearings are maintenance free. Nonetheless, it is the responsibility of the owner or guardian to periodically inspect the wheels for wear and tear, the axle for proper tightness, and bearings for side-to-side play, and loose parts. When a wheel or wheel bearing develops play, this is an indication of excess wear and replacement is necessary. Replace immediately with only genuine Razor wheels. Worn wheels/bearings are considered normal wear-and-tear and are not covered by the Razor Warranty. Wheels other than genuine Razor wheels may not be compatible with your Razor scooter. The use of anything other than genuine Razor replacement parts may affect your safety and will void your warranty.

❑ Replacement Parts

The most frequently requested replacement parts are available for purchase at some Razor retail partners. For the complete selection of replacement parts visit www.razor.com.

❑ Repair Centers

For a list of authorized Razor repair centers:

- Check online at www.razor.com.
- Additional Customer Service contact information is listed at the back of this manual.

⚠ WARNING: Keep fingers clear of the pivoting mechanism when folding or unfolding the scooter (select models only).

⚠ WARNING: Wheelies and other stunt-type riding reduces your ability to maneuver and control your scooter. Take the necessary precautions, such as wearing appropriate protective gear and practice in an area safe for stunt riding and free from obstructions.

Need Help? Visit our website for replacement parts, product support, a list of authorized service centers in the US and customer service contact information at www.razor.com. Please have the product I.D. code (located on the white label of your product) available for better assistance. Additional Customer Service contact information is listed at the back of this manual.

WARRANTY

Razor Limited Warranty

The manufacturer warrants this product to be free of manufacturing defects for a period of 6 months from date of purchase. This Limited Warranty does not cover normal wear and tear, or any damage, failure or loss caused by improper assembly, maintenance, or storage.

This Limited Warranty will be void if the product is ever:

- used in a manner other than for recreation or transportation;
- modified in any way;
- rented.

The manufacturer is not liable for incidental or consequential loss or damage due directly or indirectly to the use of this product.

Razor does not offer an extended warranty. If you have purchased an extended warranty, it must be honored by the store at which it was purchased.

For your records, save your original sales receipt with this manual and write the serial number below.

CUSTOMER SERVICE CONTACT INFORMATION

Need Help? Visit our website for product support, a list of authorized service centers in the US and customer service contact information at www.razor.com. Please have the product I.D. code (located on the white label of your product) available for better assistance. Additional Customer Service contact information is listed below:

AMERICAS

Razor USA LLC
P.O. Box 3610
Cerritos, CA 90703
USA

+1 866 467 2967
Monday - Friday
8:00 AM - 5:00 PM Pacific Time
customersupport@razorusa.com

EUROPE, MIDDLE EAST, AFRICA

Razor USA LLC (Europe)
Handelsweg 2
2742 RD Waddinxveen
Netherlands

+44 (0) 120 267 2702
info@razoreu.com

ASIA

Razor USA LLC (Asia)
P.O. Box 3610
Cerritos, CA 90703
USA

+81 50 7579 6622
info@razor-asia.com

UNITED KINGDOM AND IRELAND

Razor USA LLC (UK)
Unit 20
Hartnoll Business Centre
Post Hill, Tiverton
Devon EX16 4NG
UK

+44 (0) 120 267 2702
info@razoreu.com

AUSTRALIA AND NEW ZEALAND

Razor USA LLC (AU and NZ)
P.O. Box 4280
Auburn South VIC 3122,
Australia

+1 800 954 354 (AU)
+0 800 003 221 (NZ)
info@razoranz.com

Printed in China for Razor USA LLC.

Copyright © 2003-2021 Razor USA LLC. All rights reserved. Razor® and the Razor logo design are among the registered trademarks of Razor USA LLC and/or its affiliated companies in the United States and/or select foreign countries.

US_210410