



HOVERTRAX[™] KART

ACCESSORY KIT



OWNER'S MANUAL

**Read and understand this entire manual before allowing child to use this product! For assistance contact Razor.
DO NOT RETURN TO STORE.**

**NOTE: Manual illustrations are for demonstration purposes only.
Illustrations may not reflect exact appearance of actual product.
Specifications subject to change without notice.**

**Please have your product along with the 19 character product I.D. code with you
before contacting Razor for warranty assistance and/or replacement parts.**

Product I.D. Code: _____ - _____ - _____

CONTENTS

Introduction	1	Usage	7-8
Safety Warnings.....	1-2	Repair and Maintenance.....	8
Before You Begin.....	3	Hovertrax Kart Parts	9
Assembly and Set Up.....	4-6	Warranty and Customer Service Contact Information.....	11
Pre-Ride Checklist	7		

INTRODUCTION

This manual will help you understand, set up and safely use the Razor® Hovertrax™ Kart. It is important that you adhere to all safety warnings and cautions that appear throughout and that you use good judgment when riding, so keep reading!

SAFETY WARNINGS

⚠ WARNING: Whenever you ride the Hovertrax Kart you risk serious injury or death from collisions, falls or loss of control. To ride safely, YOU MUST READ AND FOLLOW THE INSTRUCTIONS AND WARNINGS IN THIS MANUAL.

⚠ WARNING: Riding any product can be a hazardous activity. Certain conditions may cause the equipment to fail without fault of the manufacturer. Like other ride-on products, the Razor Hovertrax Kart can and is intended to move, and it is therefore possible to lose control, fall off and/or get into dangerous situations that no amount of care, instruction or expertise can eliminate. If such things occur you can be seriously injured or die, even when using safety equipment and other precautions. RIDE AT YOUR OWN RISK AND USE COMMON SENSE.

⚠ WARNING: Failure to read and understand “How to Ride” section of this manual (page 7) increases risk of injury due to falls or other incidents.

⚠ WARNING: NOT FOR RIDERS UNDER AGE 8 OR HEAVIER THAN 176 LB (80 KG). DO NOT EXCEED THE WEIGHT LIMIT OF 176 lb (80 kg) – including backpacks and other items that might be carried. Exceeding the weight limit could injure the rider and damage the Razor Hovertrax Kart. Rider weight alone also does not necessarily mean a person’s size is appropriate to fit or maintain control of the Razor Hovertrax Kart. Keep this product away from small children and remember that this product is intended for use only by persons who are, at a minimum, completely comfortable and competent while operating the product.

Razor recommends that children under the age of 8 not be permitted to use this product. This recommendation is based not just on age or weight or height – it reflects consideration of expected maturity and skills as well as physical size. The recommended rider age of 8 years or older is only an estimate and can be affected by the rider’s size, weight, or skills – not every rider 8 years old or older will be suited to the product. Certainly, any rider unable to fit comfortably on the Razor Hovertrax Kart should not attempt to ride it, but a **parent’s decision to allow his or her child to ride this product should be based on the child’s maturity, skill, and ability to follow rules. Razor emphasizes that adults are strongly advised not to disregard Razor’s recommendations or permit younger children to ride the Razor Hovertrax Kart.**

Because products, like the Razor Hovertrax Kart, can and do present potential hazards plainly associated with their use, it is well recognized THE NEED FOR EXERCISE OF PARENTAL RESPONSIBILITY IN SELECTING RIDING PRODUCTS APPROPRIATE TO THE AGE OF A RIDER, OR PARENTAL SUPERVISION IN SITUATIONS IN WHICH CHILDREN OF VARIOUS AGES MAY HAVE ACCESS TO THE SAME RIDING PRODUCTS, IS IMPORTANT. Not every product is appropriate for every age or size of rider, and recommendations are intended to reflect the nature of the hazards and the expected mental or physical ability, or both, of a rider to cope with the hazards.

Persons with any mental or physical conditions that may make them susceptible to injury, impair their physical dexterity or mental capabilities to recognize, understand, and follow safety instructions, and to be able to understand the hazards inherent in a product’s use, should not use or be permitted to use products inappropriate for their abilities. Persons with heart conditions, head, back or neck ailments (or prior surgeries to these areas of the body), or pregnant women, should be cautioned not to operate this product.

CHECK AND MAINTAIN RAZOR HOVERTRAX KART

⚠ WARNING: Always inspect the Razor Hovertrax Kart prior to use. Properly inspecting and maintaining your product can reduce the risk of injury. Before use, check to confirm that any and all guards or covers are in place and in serviceable condition. Check that the parts are functioning properly, that the wheel is not damaged or worn excessively. The Razor Hovertrax Kart should be maintained and repaired in accordance with the manufacturer’s specifications, using only the manufacturer’s authorized replacement parts, and should not be modified from the manufacturer’s original design and configuration. Replace worn or broken parts immediately.

⚠ WARNING: Check local laws and regulations to see where and how you may use your Razor Hovertrax Kart legally. Follow all applicable laws for vehicles and pedestrians.

SAFETY GUIDELINES FOR CONTINUED USE: AN IMPORTANT MESSAGE TO ALL USERS

Periodically review this information and make sure that you understand all warnings, cautions, instructions and safety topics. Do not let others ride the Razor Hovertrax Kart until they have read this manual. Any type of wheeled activity can be hazardous. Wheels can, and are intended to move and it is therefore possible to get into dangerous situations and/or lose control and/or fall off. In such situations serious injury or death could occur.

Always be aware of the activity around you. Use the Razor Hovertrax Kart in areas free from fixed or moving hazards. Watch your surroundings for pedestrians, animals and riders of other wheeled devices.

⚠ WARNING: Only use the Razor Hovertrax Kart indoors or on completely smooth surfaces. Avoid obstacles and slippery surfaces, which could result in a loss of balance or traction and cause a fall. See the section on Terrain (page 8) for more guidelines.

Ride defensively. Watch out for potential obstacles that could catch your wheel(s) or force you to swerve suddenly or lose control. Be careful to avoid pedestrians, skaters, skateboards, scooters, bikes, children or animals who may enter your path, and respect the rights and property of others.

SAFETY WARNINGS

Never carry passengers or allow more than one person at a time to ride the product.

Never use headphones or a cell phone when riding. Never hitch a ride with another product.

NOTICE: This manual contains many warnings and cautions concerning the consequences of failing to maintain, inspect or properly use your Razor Hovertrax Kart. Because any incident can result in serious injury or even death, we do not repeat the warning of possible serious injury or death each time such a possibility is mentioned.

Do not ride the Razor Hovertrax Kart in wet or icy weather.

Wet, slick, bumpy, uneven or rough surfaces may increase risks. Do not ride this product in mud, ice, puddles or water. Avoid excessive speeds that can be associated with downhill rides. Never use near steps or swimming pools.

Do not ride at night or when visibility is limited.

Be careful and know your limitations. Risk of injury increases as the degree of riding difficulty increases. The rider assumes all risk associated with aggressive riding activities.

⚠ WARNING: Never operate any moving product, including the Razor Hovertrax Kart, while under the influence of drugs or alcohol.

PROPER RIDING ATTIRE

Always wear proper protective equipment, such as an approved safety helmet (with chin strap securely buckled). A helmet may be legally required by local law or regulation in your area. Elbow pads, kneepads, wrist guards, a long-sleeved shirt, long pants and gloves are recommended. Always wear athletic shoes (lace-up shoes with rubber soles) and keep shoelaces tied and out of the way of the wheels. Never ride barefooted or in sandals.

FAILURE TO USE COMMON SENSE AND HEED THE ABOVE WARNINGS INCREASES RISK OF SERIOUS INJURY. USE WITH APPROPRIATE CAUTION AND SERIOUS ATTENTION TO SAFE OPERATION.

BEFORE YOU BEGIN

Remove contents from box. Remove the separators that protect the components from damage during shipping. Inspect the contents of the box for scratches or dents that may have occurred during shipping. Because the Hovertrax Kart was partially assembled and packed at the factory, there should not be any problems, even if the box has a few scars or dents.

Estimated Set-Up Time

Allow up to 10 minutes for assembly.

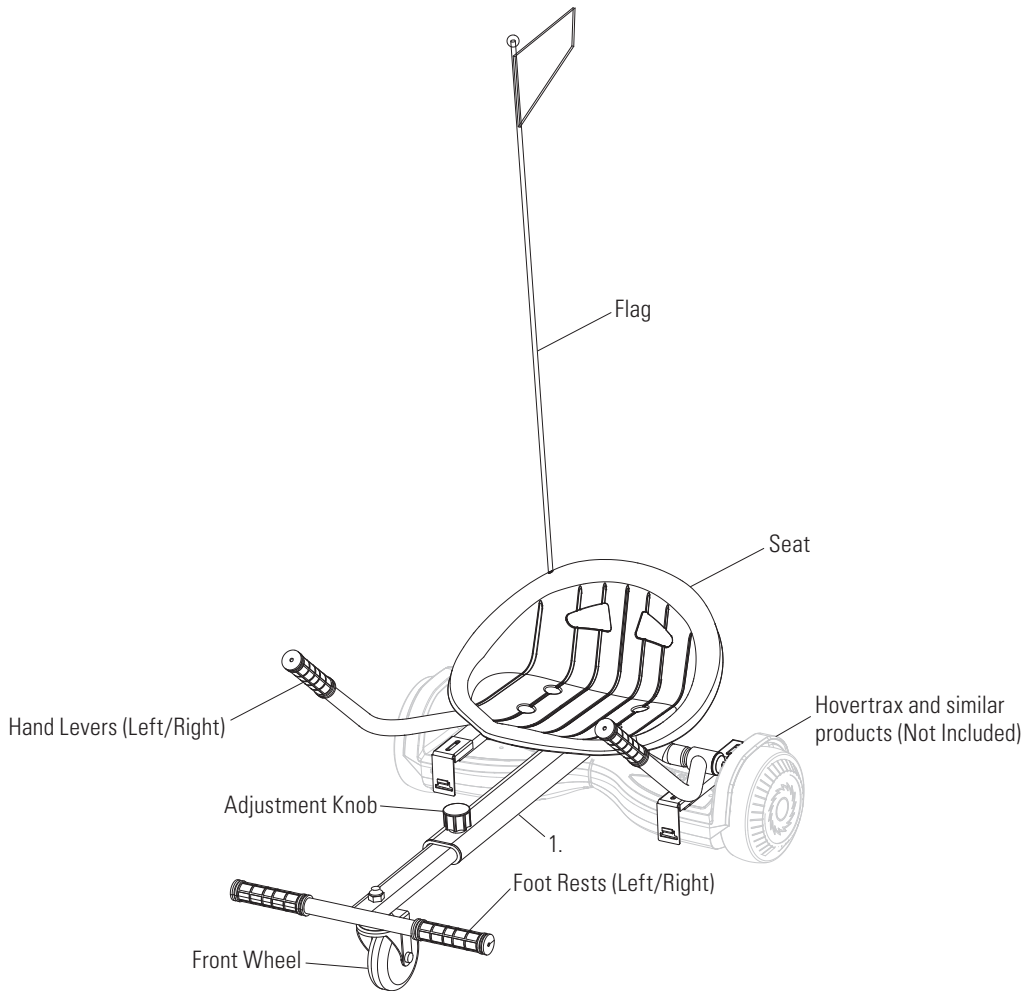

WARNING: DO NOT USE NON-RAZOR PARTS WITH YOUR PRODUCT. The Hovertrax Kart has been built to certain Razor design specifications. The original equipment supplied at the time of sale was selected on the basis of its compatibility with the frame and all other parts. Certain aftermarket components may not be compatible and will void the warranty.

Product ID Locations:

(See locations to the left)

1. Frame (Underneath Product)
2. Box - Side of UPC (Not shown)

Required Tools, Parts and Hardware

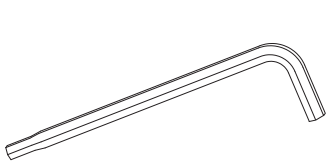

5 mm/6 mm Allen Wrench (included)

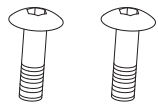

Two (2) Button Head Screws with Washers (included)



Four (4) Socket Head Screws (included)

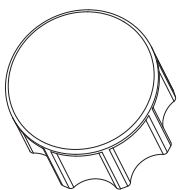

Adjustment Knob (included)

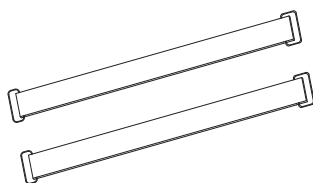

Two (2) Straps (included)

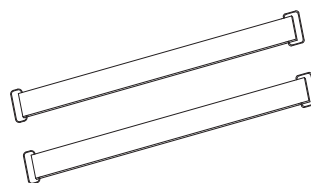

Two (2) Replacement Straps (included)

Plastic Bag Contents:

- Owner's Manual
- 5 mm/6 mm Allen Wrench
- Button Head Screws with Washers
- Socket Head Screws
- Adjustment Knob
- Straps

ASSEMBLY AND SET UP

□ Frame Assembly

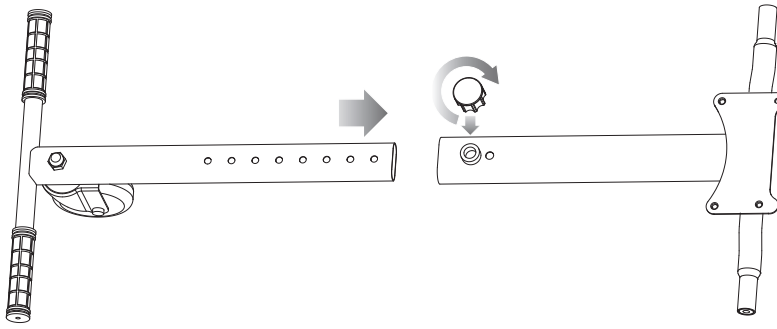

Slide the front frame into the rear frame as shown. Adjust to preferred length, and then tighten the adjustment knob to lock into place. Adjustment knob is included in plastic bag.

□ Hand Lever Assembly

Required Tool: 6 mm Allen wrench (included)

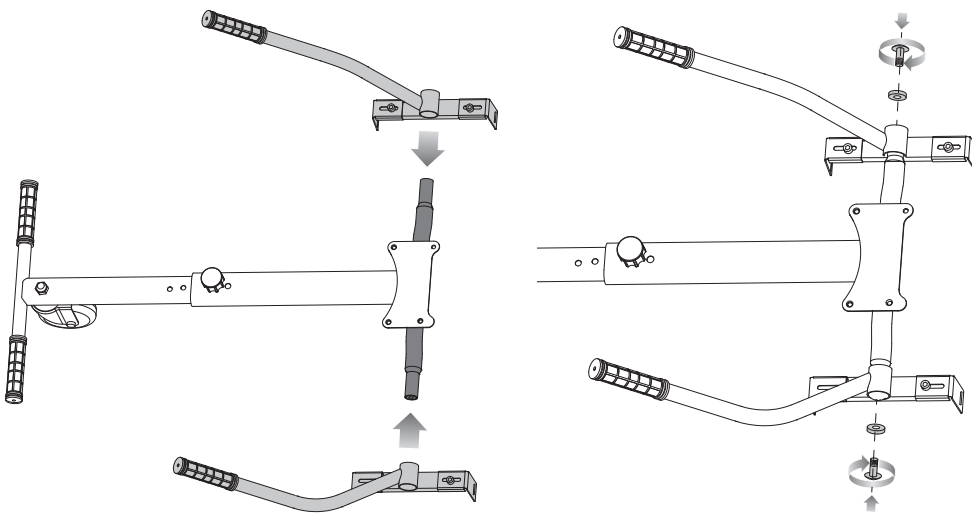

1 Insert the left and right hand levers on to the frame as shown.

2 Using washers and button head screws included in plastic bag, place washers on button head screws. Tighten securely to the frame with a 6 mm Allen wrench.

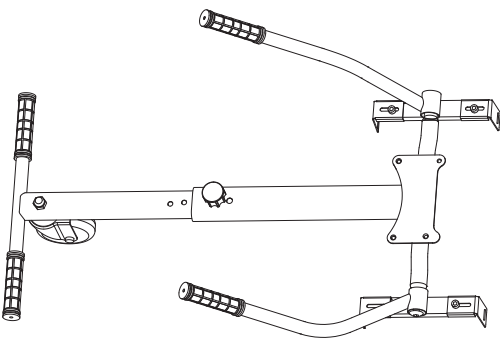

Need Help? Visit our website for replacement parts, product support, a list of authorized service centers in the US and customer service contact information at www.razor.com. Please have the product I.D. code (located on the white label of your product) available for better assistance. Additional Customer Service contact information is listed at the back of this manual.

ASSEMBLY AND SET UP

□ Seat Assembly

Required Tool: 6 mm Allen wrench (included)

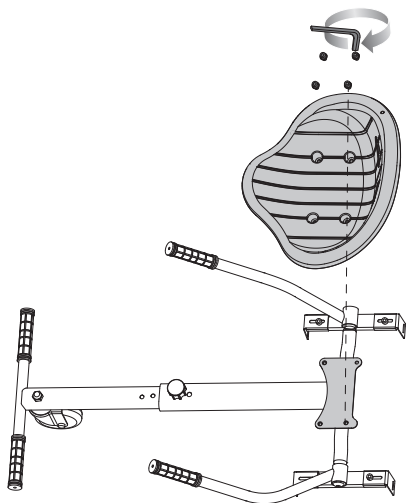

Align the four (4) holes in seat with the four (4) holes in frame. Insert the four (4) socket head screws, included in plastic bag, onto the seat and tighten securely with a 6 mm Allen wrench.

□ Attaching the Hovertrax and Similar Products (not included)

Required Tool: 5 mm Allen wrench (included)

Turn Hovertrax and similar products power switch to the OFF position before attaching to the Hovertrax Kart.

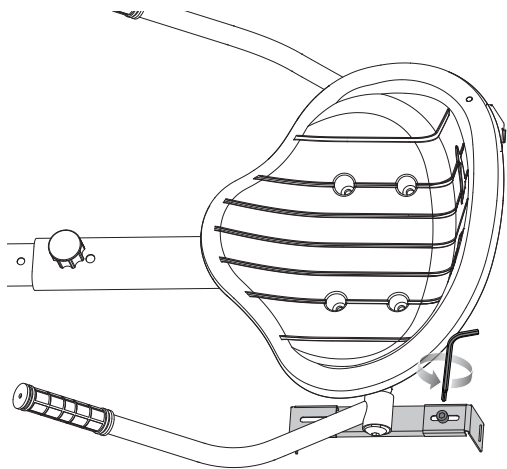

1 Using a 5 mm Allen wrench, loosen the button head screws on the left and right hand lever brackets, so that the brackets can be pulled apart.

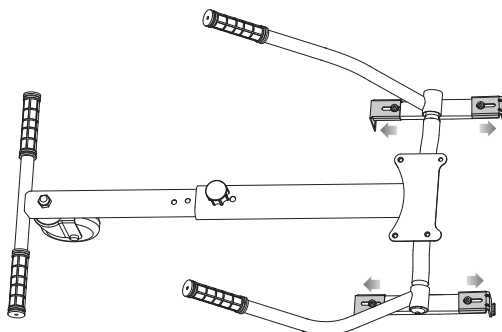

2 Pull hand lever brackets wide enough apart to allow Hovertrax Kart to be placed on to Hovertrax and similar products' (not included) foot platforms.

⚠ WARNING: Failure to properly install and tighten the socket head screws that affix seat can cause you to lose control and crash.

⚠ WARNING: Failure to properly install and tighten the button head screws and straps that affix the Hovertrax Kart to your Hovertrax and similar products can cause you to lose control and crash.

Need Help? Visit our website for replacement parts, product support, a list of authorized service centers in the US and customer service contact information at www.razor.com. Please have the product I.D. code (located on the white label of your product) available for better assistance. Additional Customer Service contact information is listed at the back of this manual.

ASSEMBLY AND SET UP

□ Attaching the Hovertrax and Similar Products (not included) Continued

Required Tool: 5 mm Allen wrench (included)

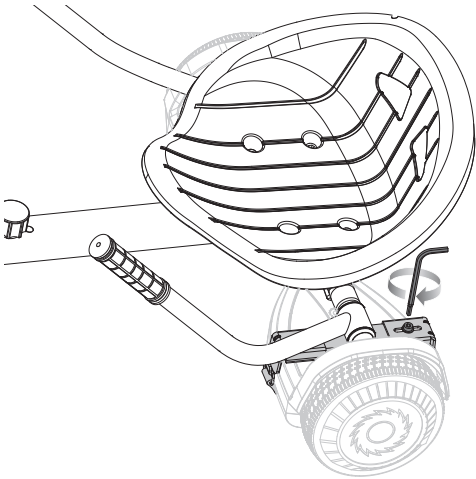

3 Once hand lever brackets are placed over the Hovertrax and similar products' foot platforms, push sides of brackets together so that brackets are tightly around Hovertrax and similar products' foot platforms. Using a 5 mm Allen wrench, tighten the button head screws on the left and right hand lever brackets, so that the Hovertrax Kart is securely attached to the Hovertrax and similar products (not included).

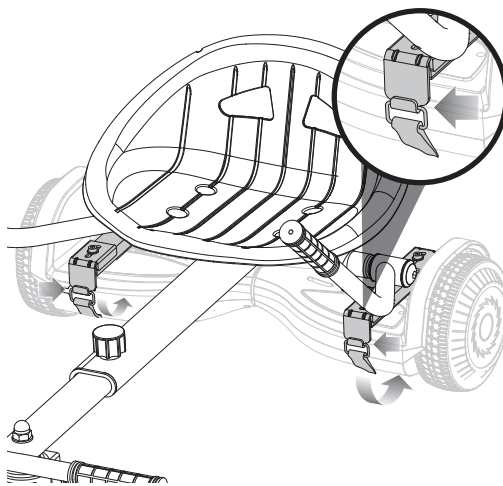

4 Hook straps to the front of the left and right hand lever brackets. Pass straps under the Hovertrax and similar products (not included).

Note: Straps may be easier to install if Hovertrax Kart and Hovertrax and similar products are upside down.

Note: Razor is not responsible for any damage that may be caused to your Razor Hovertrax or similar product by use of the Hovertrax Kart accessory kit.

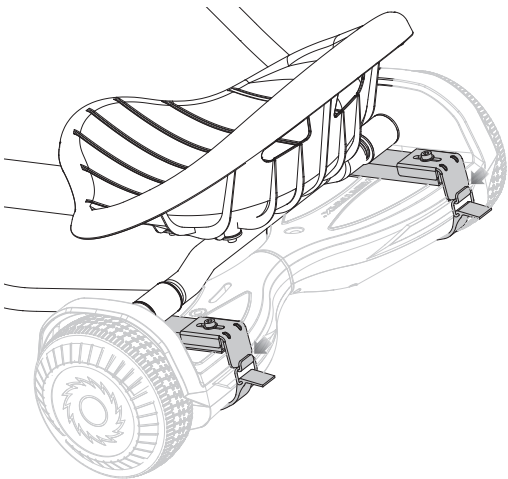

5 Hook straps onto the back of the hand lever brackets.

□ Attaching the Flag

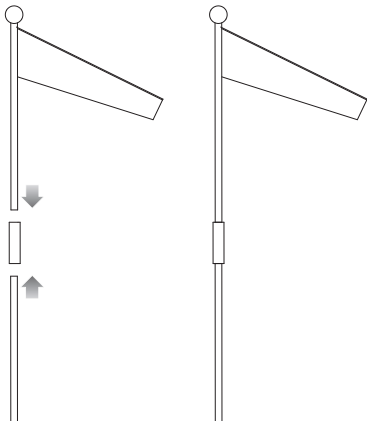

1 Assemble the flag as shown.

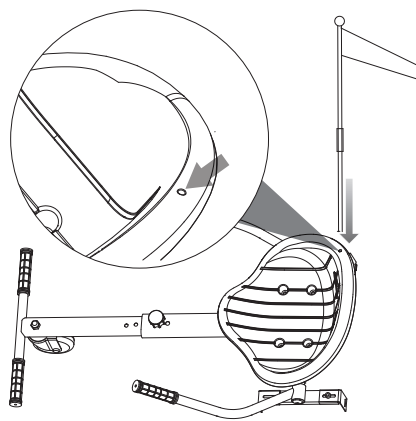

2 Insert flag into fixed hole located on seat.

PRE-RIDE CHECKLIST



Wheels

Practice riding only in wide open areas clear from curbs, parking blocks and other obstacles, including things you may fall on or into if you lose your balance. Impacting the wheels against any hard surface can damage the wheels. Wheels are not covered under your limited warranty.



Hardware/Loose Parts

Before every ride, check all parts, such as nuts, bolts, fasteners, etc., to ensure they are secure and assembled correctly. There should not be any unusual rattles or sounds from loose parts or broken components. If the product is damaged, do not ride. **Reference "Safety Warnings" on pages 1 and 2 of this manual.**



Safety Gear

Always wear proper protective gear, such as an approved safety helmet. Elbow pads, kneepads and wrist guards are recommended. Always wear athletic shoes (lace-up shoes with rubber soles) and keep shoelaces tied and out of the way of the wheels, motor and drive system. **NEVER RIDE BAREFOOTED OR IN SANDALS.**



Laws and Regulations

Always check and obey any local laws or regulations.



Storage

Prolonged exposure to UV rays, rain and the elements may damage the enclosure materials, store indoors when not in use.

USAGE

HOW TO RIDE

Thorough familiarity with the instructions and warnings for use of a Hovertrax and similar products (not included) is necessary to support use of this Hovertrax Kart accessory.

- Make sure power on Hovertrax or similar products (not included) is **OFF**. Make sure to read and follow instruction manual warnings for your Hovertrax and similar products (not included).
- Make sure Hovertrax Kart is on a flat surface and not on an incline.
- Sit on the Hovertrax Kart and place feet on the foot rests.

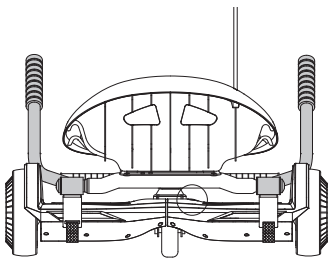

1 Pull hand levers up into a neutral position (about 45 degrees). Switch the Hovertrax or similar products' power to the **ON** position.

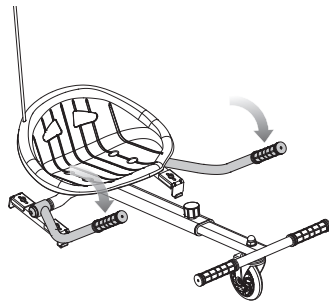

2 Push down on both hand levers to move forward.

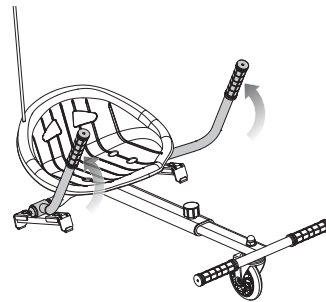

3 Pull up on both hand levers to move backwards and stop.

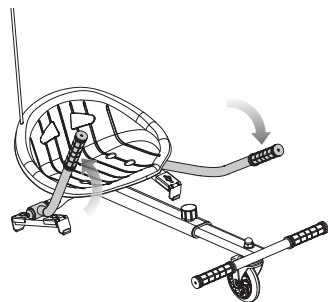

4 To turn right, push down on the left hand lever and pull up on the right hand lever.

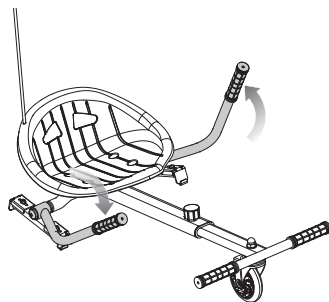

5 To turn left, push down on the right hand lever and pull up on the left hand lever.

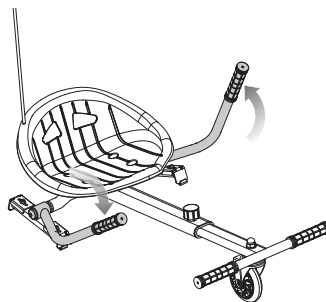

6 To spin, push/pull hand levers in opposite positions, one up, one down and maintain those hand lever positions. Return hand levers to a neutral position (about 45 degrees) to end spinning action.

⚠ WARNING: When riding, both feet must be placed securely on foot rests.

⚠ WARNING: Keep your fingers and other body parts away from the motor, steering system, wheels and all other moving components.

USAGE

HOW TO STOP

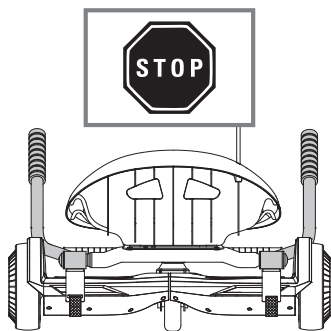

1 When you have completed your ride, return hand levers to a neutral position (about 45 degrees).

2 Switch the Hovertrax or similar products' power to the **OFF** position. Step out of Hovertrax Kart carefully.

RIDING TIPS

- Learn to ride the Hovertrax Kart in a large, safe area free from all forms of interference.
- Be alert. Scan both far ahead and in front of you - your eyes are your best tool for safely avoiding obstacles and slippery surfaces.
- Start at a slow and comfortable pace. Never aggressively accelerate or lunge forward.
- Be careful and considerate of others.
- Always ride under control at a speed that is safe for you and those around you.
- Always be prepared to stop.
- Respect pedestrians by always yielding the right of way.
- Avoid startling pedestrians. When approaching from behind, announce yourself and slow down to walking speed when passing. Pass on the left whenever possible. When approaching a pedestrian from the front, stay to the right and slow down.

TERRAIN AND AVOIDING HAZARDS, SLIPS AND TRIPS

The Hovertrax Kart is intended for indoors or use on smooth, flat surfaces. However, to prevent loss of traction, you must always be careful when riding and learn to identify and avoid slippery and wet surfaces, loose materials, slopes, potholes and other obstacles.

Stop and step out of the Hovertrax Kart over unsafe surfaces or terrain.

The Hovertrax Kart wheels must be able to grip the ground. Slips occur when the Hovertrax Kart loses traction, potentially causing loss of control and a fall. Abrupt maneuvers and riding over slippery surfaces, bumps, and loose objects and materials may cause the Hovertrax Kart to lose traction.

- Keep alert.
- Avoid riding over any surface where the undercarriage may strike an object.
- Use caution when riding over any change in terrain.

REPAIR AND MAINTENANCE

Wheel

Wheels are subject to normal wear and tear. It is the responsibility of the user to periodically inspect wheel for excess wear.

Replacement Parts

For the complete selection of replacement parts visit www.razor.com.

Repair Centers

For a list of authorized Razor repair centers:

- Check online at www.razor.com.
- Call 866-467-2967 for the center nearest you.

Need Help? Visit our website for replacement parts, product support, a list of authorized service centers in the US and customer service contact information at www.razor.com. Please have the product I.D. code (located on the white label of your product) available for better assistance. Additional Customer Service contact information is listed at the back of this manual.

HOVERTRAX KART PARTS

Keep your product working for years with genuine Razor parts. Visit our website or e-mail us for more information on spare part availability. (Specifications subject to change without notice.)

- | | | | | | | | |
|---|--|--------------------------------|---|--|---------|-----------------------|-------------------------------|
| 1. Left Hand Lever
1-1 Washer
1-2 Button Head Screw | 2. Right Hand Lever
2-1 Washer
2-2 Button Head Screw | 3. Front Frame with Foot Rests | 4. Seat Support Bracket
5. Adjustment Knob | 6. Seat
6-1 Four (4) Socket Head Screws | 7. Flag | 8. Rubber Straps (x4) | 9. Light-Up Wheel with Caster |
|---|--|--------------------------------|---|--|---------|-----------------------|-------------------------------|

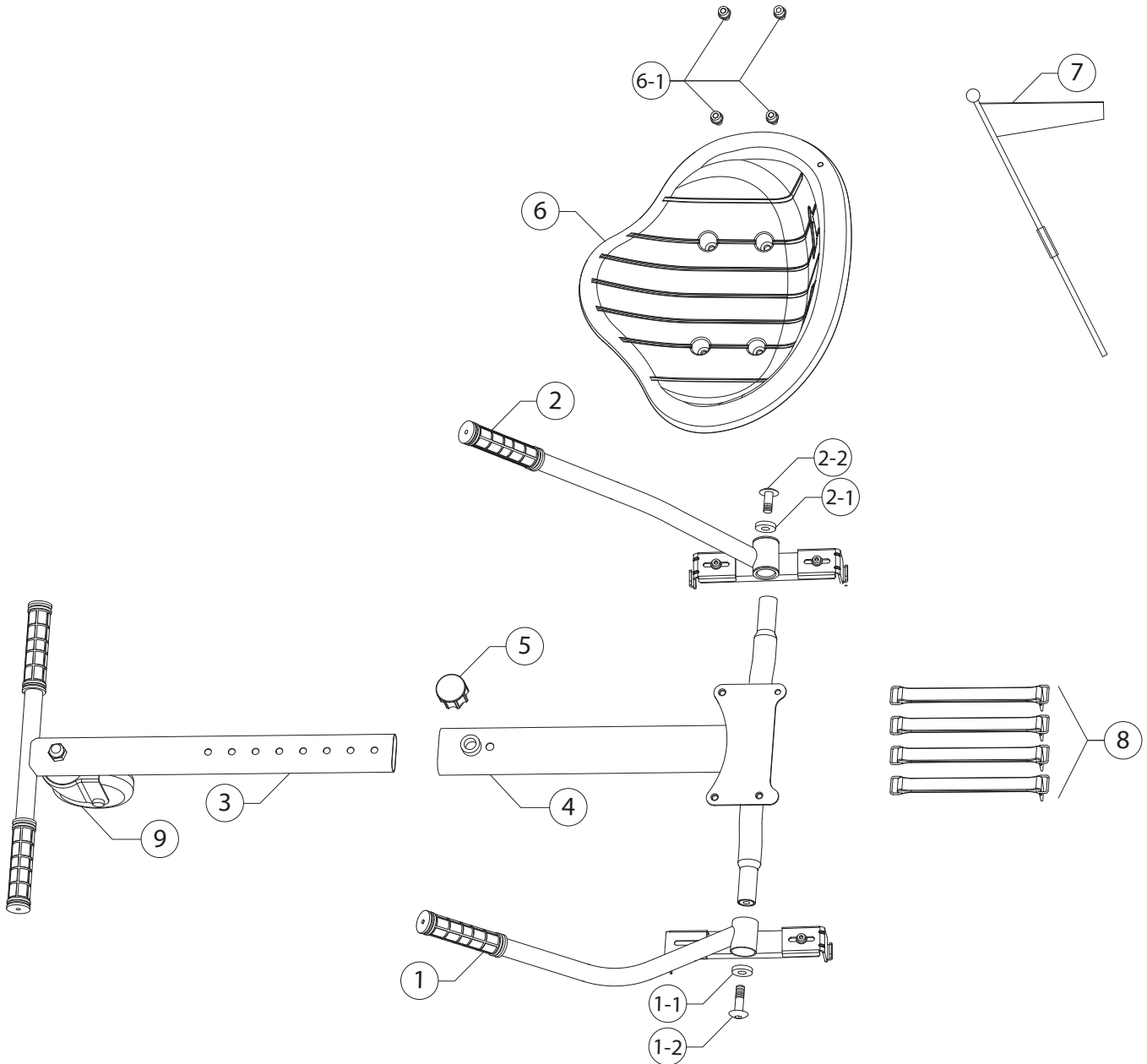

Need Help? Visit our website for replacement parts, product support, a list of authorized service centers in the US and customer service contact information at www.razor.com. Please have the product I.D. code (located on the white label of your product) available for better assistance. Additional Customer Service contact information is listed at the back of this manual.

**NOTICE: INSURANCE
YOUR INSURANCE POLICIES MAY NOT PROVIDE COVERAGE
FOR ACCIDENTS INVOLVING THE USE OF THIS SCOOTER/
RIDE-ON PRODUCT. TO DETERMINE IF COVERAGE IS PROVIDED,
YOU SHOULD CONTACT YOUR INSURANCE COMPANY OR AGENT.**

WARRANTY

Razor Limited Warranty

The manufacturer warrants this product to be free of manufacturing defects for a period of 6 months from date of purchase. This Limited Warranty does not cover normal wear and tear, wheel, or any damage, failure or loss caused by improper assembly, maintenance, storage or use of the Hovertrax Kart.

This Limited Warranty will be void if the product is ever:

- used in a manner other than for recreation or transportation;
- modified in any way;
- rented.

The manufacturer is not liable for incidental or consequential loss or damage due directly or indirectly to the use of this product.

Razor does not offer an extended warranty. If you have purchased an extended warranty, it must be honored by the store at which it was purchased.

For your records, save your original sales receipt with this manual and write the serial number below.

CUSTOMER SERVICE CONTACT INFORMATION

Need Help? Visit our website for product support, a list of authorized service centers in the US and customer service contact information at www.razor.com. Please have the product I.D. code (located on the white label of your product) available for better assistance. Additional Customer Service contact information is listed below:

AMERICAS

Razor USA LLC
P.O. Box 3610
Cerritos, CA 90703
USA

+1 866 467 2967
Monday - Friday
8:00 AM - 5:00 PM Pacific Time
customersupport@razorusa.com

EUROPE, MIDDLE EAST, AFRICA

Razor USA LLC (Europe)
Handelsweg 2
2742 RD Waddinxveen
Netherlands

+44 (0) 120 267 2702
info@razoreu.com

ASIA

Razor USA LLC (Asia)
P.O. Box 3610
Cerritos, CA 90703
USA

+81 50 7579 6622
info@razor-asia.com

UNITED KINGDOM AND IRELAND

Razor USA LLC (UK)
Unit 20
Hartnoll Business Centre
Post Hill, Tiverton
Devon EX16 4NG
UK

+44 (0) 120 267 2702
info@razoreu.com

AUSTRALIA AND NEW ZEALAND

Razor USA LLC
P.O. Box 4280
Auburn South
VIC 3122
Australia

+1 800 954 354 (AU)
+0 800 003 221 (NZ)
info@razoranz.com

IMPORTED IN JAPAN BY B-PLUS ASIA CORP.

Razor USA LLC
THE RIPSTIK COMPANY
Kurokawa 3-1, Asaoku,
Kawasaki, Kanagawa
215-0035 JAPAN

+81 (0) 44 328 9057 Tel
+81 (0) 44 328 9067 Fax
info@razor-asia.com

Printed in China for Razor USA LLC.

Copyright © 2003-2023 Razor USA, LLC. All rights reserved. Razor® and the Razor logo design are among the registered trademarks of Razor USA LLC in the United States and/or select foreign countries. Patents and Hovertrax™ trademark licensed from Inventist, Inc.