



C25™ SLA

ELECTRIC SCOOTER



! NOTE: The unit must be traveling at least 3 mph (5 km/h) before motor will engage.
Kick to start to at least 3 mph (5 km/h) while applying the throttle to engage motor.

OWNER'S MANUAL

Read and understand this entire manual before using this product!
For assistance contact Razor.
DO NOT RETURN TO STORE.

NOTE: Manual illustrations are for demonstration purposes only.
Illustrations may not reflect exact appearance of actual product.
Specifications subject to change without notice.

Please have your product along with the 19 character product I.D. code with you
before contacting Razor for warranty assistance and/or replacement parts.

Product I.D. Code: _____ - _____ - _____

CONTENTS

Safety Warnings.....	1-2	Usage.....	7-8
Before You Begin.....	3	Repair and Maintenance.....	9-10
Assembly and Set-Up.....	4-5	Troubleshooting Guide.....	11
Charging the Battery.....	5	Warranty.....	12
Pre-Ride Checklist.....	6	Contact Information.....	15

INTRODUCTION: RAZOR C25 SLA ELECTRIC SCOOTER

THE RAZOR C25 SLA IS BASED ON THE LATEST COMMUTER SCOOTERS FOR ADULT USERS AND SHOULD ONLY BE RIDDEN CAREFULLY AND RESPONSIBLY BY APPROPRIATELY MATURE AND RESPONSIBLE RIDERS EXERCISING CAUTION AND RESPECTING APPLICABLE LAWS.

The Razor C25 SLA Scooter is part of a new generation of electric scooter mobility, Razor has years of experience as a leader in motorized scooter technology, now making access to such technology more useful and appropriately available for mature riders in environments which present desirable opportunities for local travel and commutes – but which also, necessarily and importantly, can present additional levels of risk of accident due to use around cars, pedestrians and public streets.

The Razor C25 SLA, therefore, is necessarily both similar to, and in many respects different from, previous scooters. This product is not a toy for young riders! Razor emphasizes, therefore, the importance of riders to understand the risks associated with using literally any wheeled product around vehicle or pedestrian traffic and the specific risks of riding an electric scooter. Bluntly put, you could get hurt and your actions could cause injury to others. You must be cautious, alert and take reasonable precautions to minimize such risks of falls, impacts or other problems.

Generally, the Razor C25 SLA has longer battery life, multiple speed options (Low Mode up to 10 mph (16 km/h) and Sport Mode up to 15 mph (24 km/h)), and a more efficient hub motor propulsion system which makes it more amenable to “commute” uses. The user must be, and is, responsible for determining whether local laws permit use of the Razor C25 SLA in varying circumstances (there is no “uniform Federal law” in existence to establish universal riding conditions). The rider must be, and is, responsible for acting maturely, carefully, and with respect for local rules of the road when riding, and the rider must be, and is, responsible for assessing and minimizing effects of potentially adverse riding conditions including darkness or impaired visibility, fog, rain, snow, hail, ice or electrical storms, which increase dangers inherent in operating any scooter. The rider must be, and is, responsible for adjusting riding behavior and braking distance to suit the weather and traffic conditions, and also to recognize that riding in low visibility conditions decreases your ability to see and be seen, especially on public streets and around vehicles or pedestrians. The Razor C25 SLA head- and tail-lights may reduce such risks, and riders also are encouraged to seek to enhance their visibility/conspicuity through use of higher visibility garments, lights or other reflective materials when riding in reduced visibility circumstances. Razor absolutely recommends that any rider wear a proper helmet to minimize potential head injuries.

Use of the Razor C25 SLA scooter is recommended for mature riders -- using age 18+ (the generally recognized age of “legal consent”) as a guide, as do Razor’s Shared Scooters. Riders of the Razor C25 SLA certainly must respect and adhere to all locally applicable laws and rules applicable to the use of such products.

SAFETY WARNINGS

⚠ WARNING: Riding a C25 SLA does present potential risks and caution is required. Like any riding product, a C25 SLA has inherent hazards associated with its use (for example, falling off or riding it into a hazardous situation). Like any riding product, the C25 SLA can and is intended to move and it is therefore, of course, possible to lose control or otherwise get into dangerous situations. Riders must recognize that if such things occur, a rider can be seriously injured or die even when using safety equipment and other precautions. RIDE AT YOUR OWN RISK AND USE COMMON SENSE.

⚠ WARNING: Always check and obey any local laws or regulations which may affect the locations where the C25 SLA may be used. Keeping away from cars and motor vehicle traffic provides the highest protection against risk of traffic-related injuries, of course. For mature riders seeking to operate this product as legally permitted for commuting applications, the increased risks presented by traffic certainly emphasizes that the need for caution, personal responsibility and compliance with local laws is imperative and is the rider’s responsibility. Only use where allowed and with caution.

⚠ WARNING: PARENTAL AND ADULT RESPONSIBILITY AND SUPERVISION IS NECESSARY TO ASSURE USE BY MATURE RIDERS:

Because products, like the C25 SLA electric scooter, can and do present potential hazards plainly associated with their use, it is well recognized THE NEED FOR EXERCISE OF PARENTAL RESPONSIBILITY IN SELECTING RIDING PRODUCTS APPROPRIATE TO THE AGE OF A CHILD, OR PARENTAL SUPERVISION IN SITUATIONS IN WHICH CHILDREN OF VARIOUS AGES MAY HAVE ACCESS TO THE SAME RIDING PRODUCTS, IS IMPORTANT. Not every product is appropriate for every age or size of child, and different age recommendations are found within this category of product which are intended to reflect the nature of the hazards and the expected mental or physical ability, or both, of a child to cope with the hazards.

⚠ WARNING: NOT FOR RIDERS UNDER AGE 18 OR HEAVIER THAN 220 LB (100 KG). DO NOT EXCEED THE WEIGHT LIMIT OF

220 lb (100 kg) – including backpacks and other items that might be carried. Exceeding the weight limit could injure the rider and damage the C25 SLA. Rider weight alone also does not necessarily mean a person’s size is appropriate to fit or maintain control of the C25 SLA. Keep this product away

SAFETY WARNINGS

from small children and remember that this product is not a toy and is intended for use only by persons who are, at a minimum, completely comfortable and competent while operating the product.

Razor recommends that children under the age of 18 not be permitted to use this product. This recommendation is based not just on age or weight or height; it reflects consideration of expected maturity and skills as well as physical size. The recommended rider age of 18 years or older is only an estimate and can be affected by the rider's size, weight, or skills – not every rider 18 years old or older will be suited to the product. Certainly, any rider unable to fit comfortably on the C25 SLA should not attempt to ride it, but **a parent's decision to allow his or her child to ride this product should be based on the child's maturity, skill, and ability to follow rules. Razor emphasizes that adults are strongly advised not to disregard Razor's recommendations or permit younger children to ride the C25 SLA.**

Keep this product away from small children and remember that it is intended for use only by persons who are, at a minimum, completely comfortable and competent while operating.

Persons with any mental or physical conditions that may make them susceptible to injury, impair their physical dexterity or mental capabilities to recognize, understand, and follow safety instructions and to be able to understand the hazards inherent in the use of any ride-on product, should not use or be permitted to use products inappropriate for their abilities. Persons with heart conditions, head, back or neck ailments (or prior surgeries to these areas of the body), or pregnant women, should be cautioned not to operate such products.

DO NOT EXCEED THE WEIGHT LIMIT OF 220 lb (100 kg). Rider weight does not necessarily mean a person's size is appropriate to fit or maintain control of the C25 SLA.

CHECK AND MAINTAIN PRODUCT CONDITIONS

Before use, check to confirm that covers and guards are in place and in serviceable condition. Check that the brakes and lights are functioning properly, that the tires are inflated properly and have sufficient tread remaining. The product should be maintained and repaired in accordance with the manufacturer's specifications, using only the manufacturer's authorized replacement parts, and should not be modified from the manufacturer's original design and configuration.

ACCEPTABLE RIDING PRACTICES AND CONDITIONS

Do not activate the throttle unless you are on the C25 SLA and in a safe, outdoor environment suitable for riding. **The electric scooter must be moving at least 3 mph (5 km/h) before the motor will engage.** Once the throttle is activated the C25 SLA will move forward.

The normal powered top speed of this product will be approximately 15 mph (24 km/h), which can be affected by conditions, such as rider weight, inclines and battery charge level. Avoid excessive speeds that can be associated with downhill rides.

Maintain a hold on the handlebars at all times. Do not touch the brakes or motor on your scooter when in use or immediately after riding, as these parts can become very hot.

Ride defensively. Watch out for potential obstacles that could catch your wheel or force you to swerve suddenly or lose control. Be careful to avoid pedestrians, skaters, skateboards, scooters, bikes, children or animals who may enter your path, and respect the rights and property of others.

The C25 SLA is intended for use on flat, dry surfaces, such as pavement or level ground, without loose debris, such as sand, leaves, rocks or gravel. Wet, slick, bumpy, uneven or rough surfaces may impair traction and contribute to possible accidents. Do not ride your product in mud, ice, puddles or water. Watch out for potential obstacles that could catch your wheel or force you to swerve suddenly or lose control. Avoid sharp bumps, drainage grates, and sudden surface changes.

Do not attempt or do stunts or tricks. The C25 SLA is not made to withstand abuse from misuse, such as jumping, curb grinding or any other type of stunts. Racing, stunt riding, or other maneuvers also enhance risk of loss of control, or may cause uncontrolled rider actions or reactions.

Never allow more than one person at a time to ride the product.

Riding at night or when visibility is limited increases risks of accident or injury. Should the C25 SLA scooter be ridden in such conditions, use of lights and additional measures to increase rider visibility and scooter conspicuity are advised.

Never use near steps or swimming pools.

The C25 SLA electric scooter can operate more quietly than other motorized products may operate. Use care when in the vicinity of pedestrians or others who may have difficulty hearing your approach. Use handbell (not included) to sound warnings when appropriate.

Do not allow hands, feet, hair, body parts, clothing, or similar articles to come in contact with moving parts or wheels while the motor is engaged.

Do not touch electric motor or brakes when in use or immediately after riding.

Never use headphones or a cell phone to talk or text when riding.

Never ride your product while under the influence of drugs or alcohol.

Never hitch a ride with a vehicle.

PROPER RIDING ATTIRE

Always wear proper protective equipment, such as an approved safety helmet (with chin strap securely buckled), elbow pads, and kneepads. A helmet may be legally required by local law or regulation in your area. A long-sleeved shirt, and long pants are recommended. Always wear shoes and keep shoelaces tied and out of the way of the wheels and motor. Never ride barefooted or in sandals.

USING THE CHARGER

The charger supplied with the product should be regularly examined for damage to the cord, plug, enclosure and other parts. In the event of such damage, the product must not be charged until the charger has been repaired or replaced.

Use only with the recommended charger.

Use caution when charging.

The charger is not a toy. Charger should be operated by an adult.

Do not operate charger near flammable materials.

Unplug charger and disconnect from product when not in use.

Always disconnect from the charger prior to wiping down and cleaning your product with damp cloth.

FAILURE TO USE COMMON SENSE AND HEED THE ABOVE WARNINGS FURTHER INCREASES RISK OF SERIOUS INJURY. USE AT YOUR OWN RISK AND WITH APPROPRIATE AND SERIOUS ATTENTION TO SAFE OPERATION. USE CAUTION.

BEFORE YOU BEGIN

Remove contents from box. Remove the separators that protect the components from damage during shipping. Inspect the contents of the box for scratches in the paint, dents that may have occurred during shipping. Because your scooter was partially assembled and packed at the factory, there should not be any problems, even if the box has a few scars or dents.

MAKE SURE POWER SWITCH IS TURNED "OFF" BEFORE CONDUCTING ANY ASSEMBLY OR MAINTENANCE PROCEDURES.

Estimated Assembly and Set-Up Time

Razor recommends assembly by an adult.

Allow up to 15 minutes for assembly, not including initial charge time.

Allow up to 12 hours for charge (see page 5 for charging information).

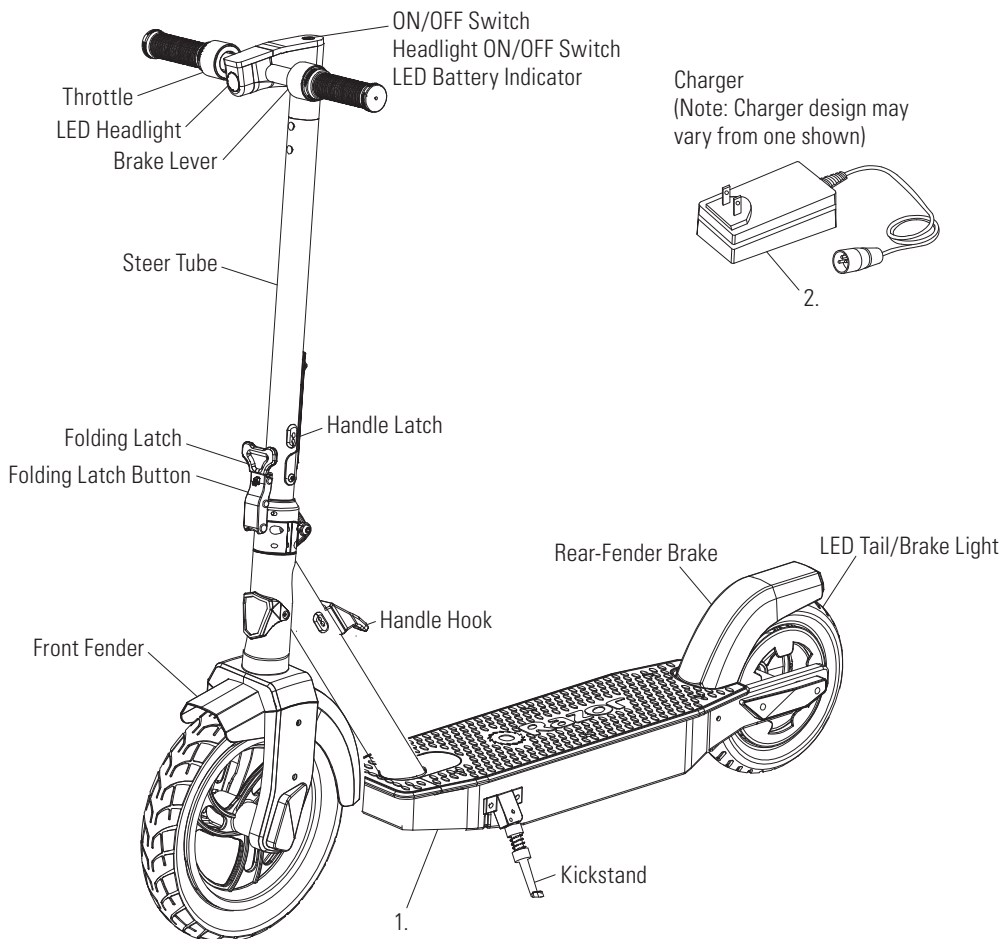

WARNING:

DO NOT USE NON-RAZOR PARTS WITH YOUR RAZOR ELECTRIC SCOOTER. Razor scooters have been built to certain Razor design specifications. The original equipment supplied at the time of sale was selected on the basis of its compatibility with the frame and all other parts. Certain aftermarket components may not be compatible. Use of non-Razor parts will void the warranty.

Note: Electric scooter must be moving at least 3 mph (5 km/h) while applying throttle to engage motor.

Product ID Locations:

(See locations to the left)

1. Side of Deck
2. Charger
3. UPC Side of Box (Not Shown)

Required Tools and Parts

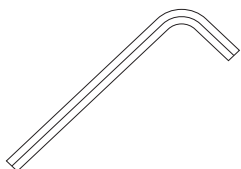

4 mm Allen Wrench
(Included)

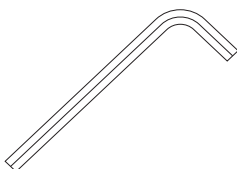

2.5 mm Allen Wrench
(Included)

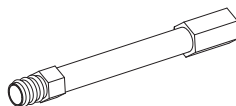

Tire Valve Adapter
(Included)

Box Contents:

- C25 SLA
- Charger
- Owner's Manual
- 4 mm Allen Wrench
- 2.5 mm Allen Wrench
- Tire Valve Adapter

Need Help? Visit our website for replacement parts, product support, a list of authorized service centers in the US and customer service contact information at www.razor.com. Please have the product I.D. code (located on the white label of your product) available for better assistance. Additional Customer Service contact information is listed at the back of this manual.

ASSEMBLY AND SET-UP

□ Unfolding the Scooter for First Time Use

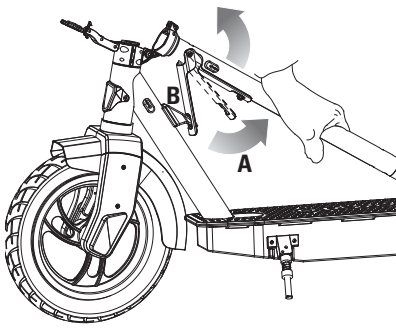

1 To unfold scooter, disengage the Handle Latch (A) from the Handle Hook (B) and stow the Handle Latch against the Steer Tube.

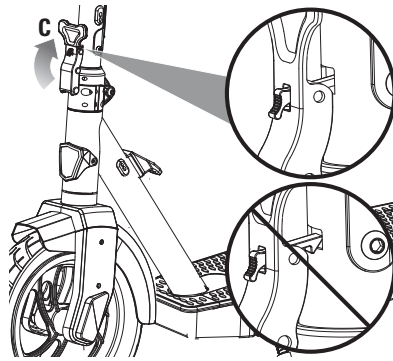

2 With the Steer Tube upright, secure the Folding Latch (C) by pushing open Folding Latch up against the Steer Tube to lock in place. Once secured, pull out on the Folding Latch (C) to test that it's engaged and locked.

⚠ WARNING: Keep fingers clear of the pivoting mechanism when folding or unfolding the scooter. Make sure others are standing clear.

□ Attaching the Handlebars

Required Tool: 4 mm Allen wrench (included)



1 Before inserting the handlebars onto the Steer Tube, pull the connector through and remove the rubber protector. Discard rubber protector.

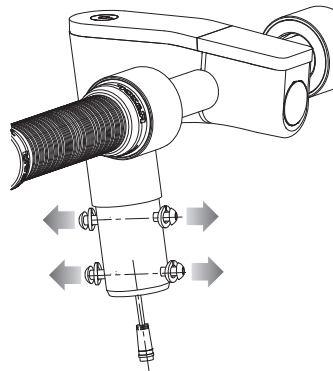

2 Using a 4 mm Allen wrench, remove the four (4) Allen screws and washers from the handlebar.

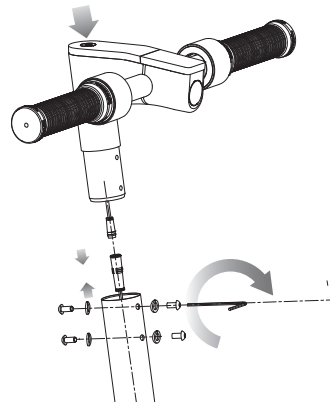

3 Plug in connector. Slide the stem onto the Steer Tube. Be careful not to pinch wire. Tighten the four (4) handlebar screws and washers securely with a 4 mm Allen wrench.

□ Inflating the Front Tire

The front tire is inflated when shipped, but it invariably may lose some pressure between the point of manufacturing and your purchase. **Always inflate tire to the correct PSI before first time use.**

Lower air pressure can result in a shorter ride time.

Periodically check front tire. Reinflate when needed.

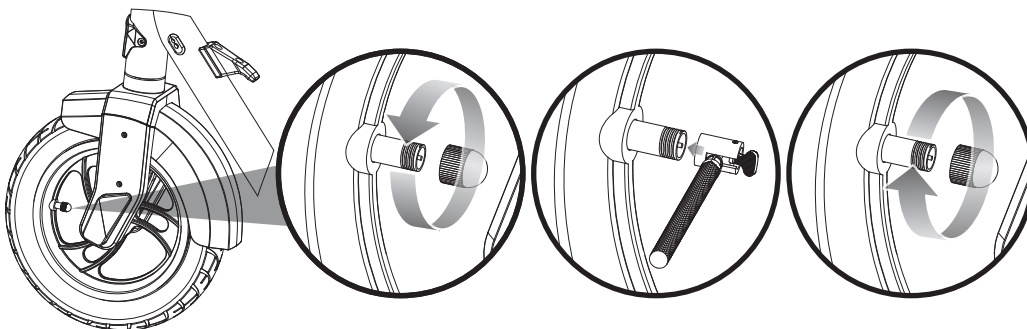

1 Remove the valve cap and using a bicycle style tire pump equipped for a Schrader-type valve, inflate the front tire to the correct PSI indicated on the sidewall of the tire. Replace the valve cap.

⚠ WARNING: Do not use the electric scooter for the first time until you have inflated the front tire to the correct PSI. Failure to do so may damage your electric scooter and void your warranty.

⚠ WARNING: Do not overinflate, as this could damage the tire or wheel.

Note: The pressure air supplies found at gasoline stations are designed to inflate high-volume automobile tires. If you decide to use such an air supply to inflate your electric scooter tire, first make sure the pressure gauge is working, then use very short bursts to inflate to the correct PSI. If you inadvertently overinflate the tire, release the excess pressure immediately.

ASSEMBLY AND SET-UP

□ Inflating the Rear Tire

Required Tool: Tire Valve Adapter (included)

The rear tire is inflated when shipped, but it invariably may lose some pressure between the point of manufacturing and your purchase. **Always inflate tire to the correct PSI before first time use.**

Lower air pressure can result in a shorter ride time.

Periodically check front tire. Reinflate when needed.

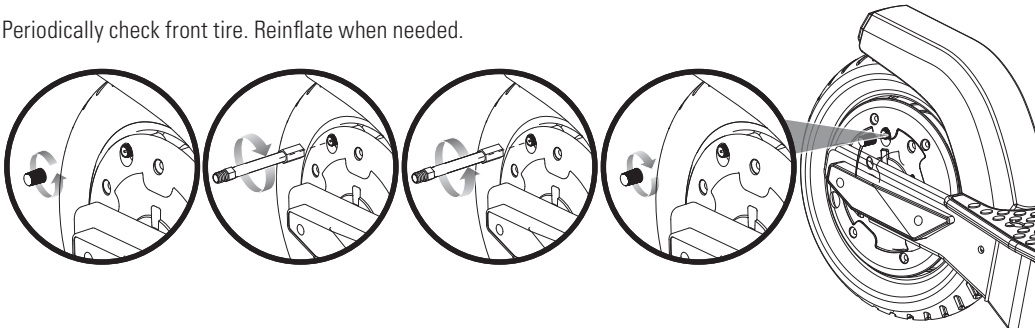

1 Remove the valve cap and install the tire valve adapter. Using a bicycle style tire pump equipped for a Schrader-type valve, inflate the rear tire to the correct PSI indicated on the sidewall of the tire. Remove adapter and replace the valve cap. Save the tire valve adapter for future use.

⚠ WARNING: Do not use the electric scooter for the first time until you have inflated the rear tire to the correct PSI. Failure to do so may damage your electric scooter and void your warranty.

⚠ WARNING: Do not overinflate, as this could damage the tire or wheel.

Note: The pressure air supplies found at gasoline stations are designed to inflate high-volume automobile tires. If you decide to use such an air supply to inflate your electric scooter tire, first make sure the pressure gauge is working, then use very short bursts to inflate to the correct PSI. If you inadvertently overinflate the tire, release the excess pressure immediately.

CHARGING THE BATTERY

Your C25 SLA may not have a fully charged battery; therefore you must charge the battery prior to use. Be sure to charge the battery in a clean, dry location away from direct sunlight, flames or sparks.

- Initial charge time: 12 hours.
- Recharge time: up to 6 hours, even if the light turns green. Recommended maximum charging time is 24 hours.
- Always charge the battery immediately after riding.
- Fully charge battery before storing for extended periods of time.
- Unplug charger from the wall outlet when not in use.
- Failure to recharge battery periodically may result in a battery that will not accept a charge.
- Make sure the power button is turned OFF when product is not in use. If the power button is left on for an extended period of time, the battery may reach a stage at which it will no longer hold a charge.
- To ensure long battery life, never store the product in freezing or below freezing temperatures! Freezing will permanently damage the battery.
- Run time: Up to 40 minutes of continuous ride time. Run time may vary depending on riding conditions, rider weight, climate, and/or proper maintenance.
- Constant starting and stopping may shorten ride time.
- Battery life can vary depending on proper maintenance and usage of the product.
- Do not charge at or below 32°F (0°C).

⚠ WARNING: Use ONLY with the recommended charger. Batteries are only to be charged under adult supervision. The charger is not a toy. Always disconnect the charger before wiping down and/or cleaning the C25 SLA with a damp cloth.

The charger supplied with the C25 SLA should be regularly examined for damage to the cord, plug, enclosure and other parts. In the event of such damage, the C25 SLA must not be charged until it has been repaired or replaced.

Chargers have built-in overcharge protection to prevent battery from being overcharged.

Note: If the charger gets warm during regular use, this is a normal response and is no cause for concern. If your charger does not get warm during use, it does not mean that it is not working properly.

Wall outlet - Green (stand by)
Wall outlet and unit - Red (charging)
Wall outlet and unit - Green (charged)

Note: Continue charging unit even if light turns green prior to 8 hours.

⚠ WARNING: Battery charge can deplete over time. Periodically recharge battery when not in use.

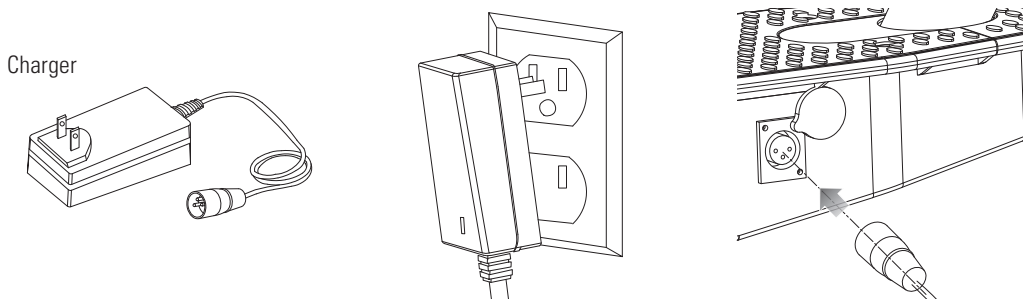

Charger
(Note: Charger design may vary from one shown)

1 Plug the charger plug into wall outlet. The light on the charger should be green.

Note: If green light (LED) does not turn on, try a different outlet.

2 Note: Make sure power button is in the OFF position. Plug the charger into the charger port. The light on the charger should turn red during charging. The light will turn green again when charging is complete.

Model	Voltage (Nominal) Vdc	Capacity (Nominal) Ah	Charge Temperature Range	Operating Temperature Range
C25 SLA	36	5	-10° to 50°C 14° to 122°F	-10° to 50°C 14° to 122°F

PRE-RIDE CHECKLIST



Lights

Check the head- and tail-lights for proper function. When you activate the lights (reference "How to Ride" on page 7 of this manual), the headlight and taillight should illuminate.



Brakes

Check the brake and brake lights for proper function. When you squeeze the brake lever (on handlebar) the brakes should provide positive braking action and tail/brake light should illuminate. When you apply the brakes with the throttle on/engaged, the brake cut-off switch should cut power to the motor.



Wheels

Periodically inspect the wheels for excessive wear.



Tires

Periodically inspect the tires for excess wear and replace as needed. Regularly check the tire pressure and inflate as needed.



Frame, Fork and Handlebars

Check for cracks or broken connections. Although broken frames are rare, it is possible for an aggressive rider to run into a curb or object and wreck, bend or break a frame. Get in the habit of inspecting your scooter on a regular basis.



Hardware/Loose Parts

Before every ride, check all parts, such as nuts, bolts, fasteners, etc., to ensure they are secure and assembled correctly. There should not be any unusual rattles or sounds from loose parts or broken components. If the product is damaged, do not ride. **Reference "Safety Warnings" on pages 1 and 2 of this manual.**



Safety Gear

Always wear proper protective equipment, such as an approved safety helmet (with chin strap securely buckled), elbow pads, and kneepads. A helmet may be legally required by local law or regulation in your area. A long-sleeved shirt and long pants are recommended. Always wear shoes and keep shoelaces tied and out of the way of the wheels and drive system. **NEVER RIDE BAREFOOTED OR IN SANDALS.**



Laws and Regulations

Always check and obey any local laws or regulations.



Insurance

Do not assume that your existing insurance policies necessarily provide coverage for electric product use. Check with your insurance company for information regarding insurance.



Storage

Prolonged exposure to UV rays, rain and the elements may damage the enclosure materials, store indoors when not in use.

USAGE

□ How to Ride

Do not activate the thumb throttle unless you are on the C25 SLA and in a safe, outdoor environment suitable for riding.

Put kickstand up.

Press the power button **(A)** for two seconds, the LEDs on the battery display will light up. Press the power button **(A)** for two seconds again to turn the unit off.

Headlight and Taillight: To activate the headlight and taillight the product must be powered **ON**. Press the power button **(A)** once to activate the headlight and taillight. To deactivate the headlight and taillight, press the power button **(A)** once again.

Get on the scooter and place both hands on the handlebars. Kick to start **(B)**, and then press down on the thumb throttle **(C)**.

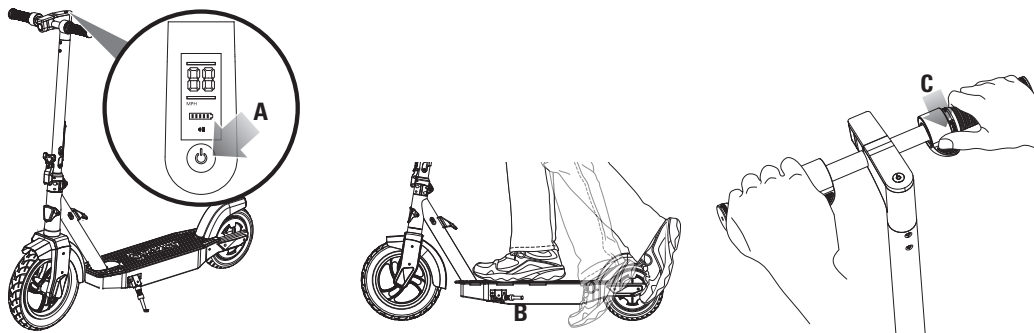

Note: Electric scooter must be moving at least 3 mph (5 km/h) while engaging throttle to engage motor.

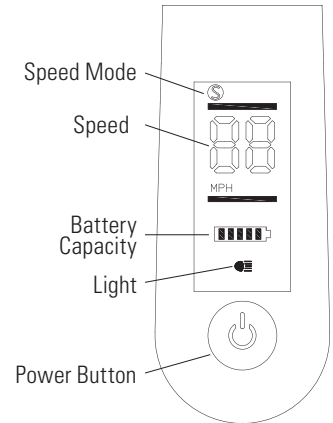

□ How to Stop

For controlled stops, apply the brake by pressure on the rear-fender brake or electronic brake (on handlebar). Razor recommends that you practice applying the brake options at various speeds and in an open area free from obstructions before riding your scooter around others.

When the brake is applied the tail/brake light will glow brighter. The brake light is always functional and independent of the other lights being activated.

Option 1 - Press the electronic brake (on handlebar), the power will cut off and then product will slow to a stop.

Option 2 - Step on the rear-fender brake, the power will cut off and then product will slow to a stop.

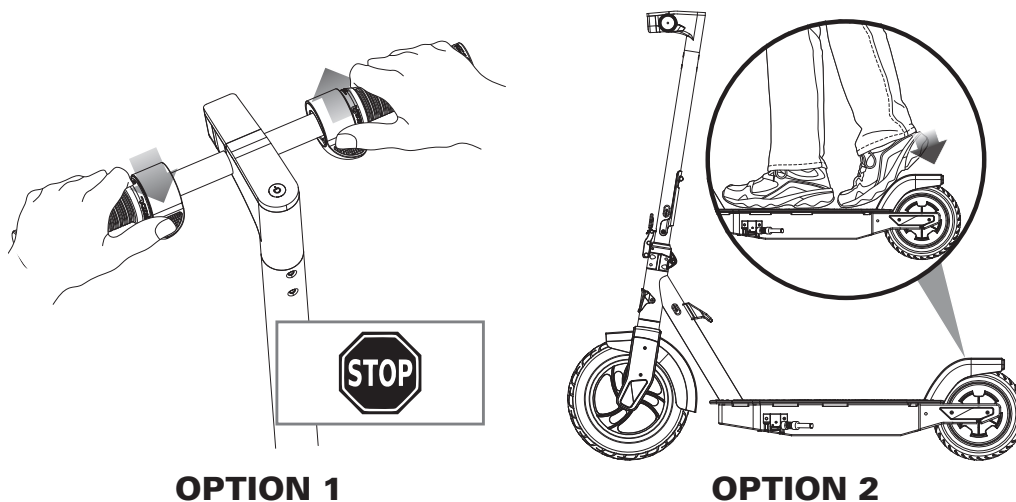

⚠ WARNING: The brakes are capable of skidding the rear tire and throwing an unsuspecting rider. Practice in an open area free from obstacles until you are familiar with the brake function. Avoid skidding to a stop as this can cause you to lose control and/or damage the rear tire.

Note: As an additional safety feature, the scooter is designed to cut power to the motor when the brakes are applied.

Note: Motor will re-engage, (without having to kick to start), if brakes are released and throttle is applied **before** scooter has slowed down to **under 3 mph (5 km/h)**.

Note: Practice riding only in wide open areas clear from curbs, parking blocks and other obstacles. Impacting the wheels against any hard surface can damage the wheels. Wheels are not covered under the limited warranty.

Note: The C25 SLA electric scooter features **Regenerative Braking**. Regenerative braking is a means of recovering and converting kinetic energy into stored power. Using the scooter's electric motor, energy that is usually lost during deceleration and braking is captured and converted back to stored power extending run time and range. Regenerative braking only recovers a small amount of energy at a time but can be significant over the course of a full battery cycle. As always specifications and the amount of recovered regeneration varies with rider weight, terrain, and environmental conditions.

Need Help? Visit our website for replacement parts, product support, a list of authorized service centers in the US and customer service contact information at www.razor.com. Please have the product I.D. code (located on the white label of your product) available for better assistance. Additional Customer Service contact information is listed at the back of this manual.

USAGE

□ Changing the Speed Mode

There are two modes for speed. The C25 SLA is set on the Low (10 mph (16km/h)) speed setting at the factory. Press power button twice quickly to select the speed mode.

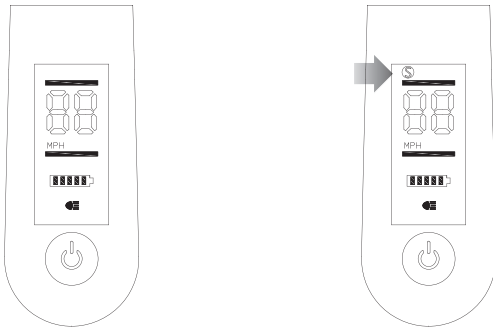

1 The Low mode max speed is up to 10 mph (16 km/h).

2 The Sport mode max speed is up to 15 mph (24 km/h) as shown by an "S" at the top of the display.

□ Folding Scooter

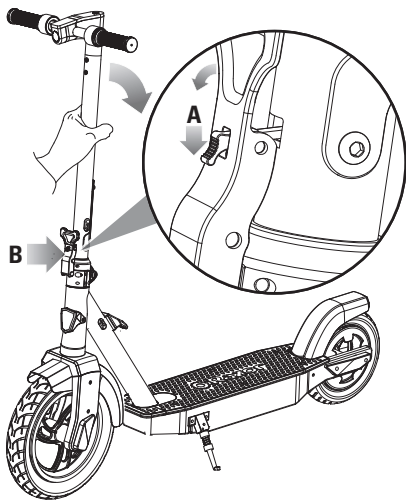

1 To fold scooter, press and hold down the Folding Latch Button (A) while pulling the Folding Latch (B) open.

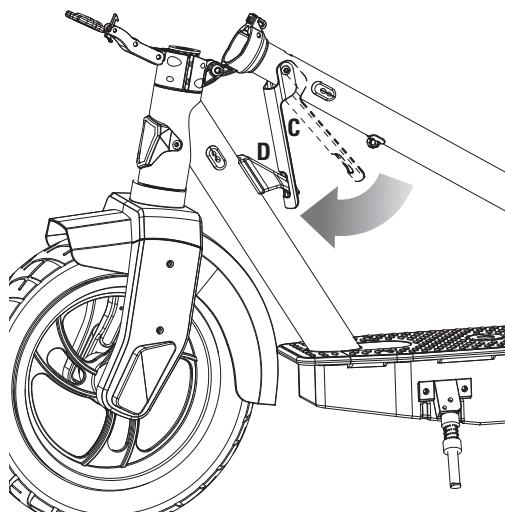

2 To use the Steer Tube as a carrying handle, deploy the Handle Latch (C) and engage the Handle Hook (D) on the frame.

Note: The C25 SLA display default setting is in miles. If you would like to change the display setting to kilometers, press the power button (A) three times quickly to select the kilometers setting.

⚠ WARNING: Keep fingers clear of the pivoting mechanism when folding or unfolding the scooter. Make sure others are standing clear.

REPAIR AND MAINTENANCE

Turn power switch "OFF" before beginning repair or maintenance:

- Read the instructions
- Remove charger plug
- Turn the power off
- Secure the product under repair
- Exercise caution around exposed parts
- Contact Razor customer service if unsure about any repair or maintenance
- Repair and maintenance should be performed by an adult only

□ Adjusting the Folding Mechanism

Required Tool: 2.5 mm Allen Wrench (included)

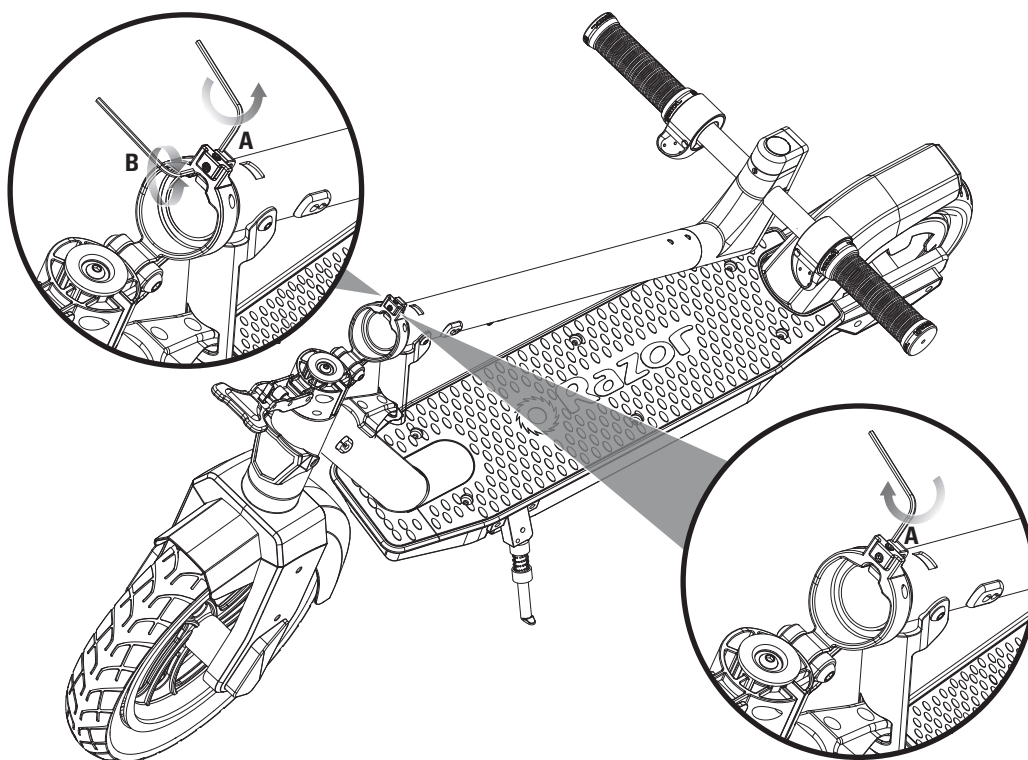

1 Fold scooter according to folding scooter instructions on page 8. Using a 2.5 mm Allen wrench, loosen screw **A**. Using a 2.5 mm Allen wrench adjust screw **B**.

2 Tighten screw **A** and unfold to complete adjustment.

REPAIR AND MAINTENANCE

Note: Risk of fire - no user serviceable parts.

□ Cleaning Your Scooter

Wipe with a damp cloth to remove dirt and dust. Do not use industrial cleaners or solvents as they may damage the surfaces. Do not use alcohol, alcohol-based or ammonia-based cleaners as they may damage or dissolve the plastic components or soften the decals or decal adhesive.

□ Battery Care and Disposal

Do not store in freezing or below freezing temperatures. To properly maintain your battery and ensure maximum battery life, carefully read the "Charging the Battery" section on page 5 of this owner's manual.



CONTAINS SEALED LEAD-ACID BATTERY. BATTERY MUST BE RECYCLED.

Disposal: Your Razor product uses sealed lead-acid battery which must be recycled or disposed of in an environmentally safe manner. Do not dispose of a lead-acid battery in a fire. The battery may explode or leak. Do not dispose of a lead-acid battery in your regular household trash. The incineration, land filling or mixing of sealed lead-acid batteries with household trash is prohibited by law in most areas. Return exhausted battery to a federal or state approved lead-acid battery recycler or a local seller of automotive batteries. If you live in Florida or Minnesota, it is prohibited by law to throw away lead-acid batteries in the municipal waste stream.

□ Charger

The charger supplied with the electric scooter should be regularly examined for damage to the cord, plug, enclosure and other parts and in the event of such damage, the product must not be charged until it has been repaired or replaced.

Use **ONLY** with the recommended charger.

Not intended for use at elevations greater than 2000 m above sea level.

□ Wheels

Wheels and drive system are subject to normal wear and tear. It is the responsibility of the user to periodically inspect wheels for excess wear and replace hub motor components as required.

□ Repair Centers

For a list of authorized Razor repair centers:

- Check online at www.razor.com.
- Additional Customer Service contact information is listed on the back of this manual.



In the US and Canada only:

For more information regarding recycling of rechargeable batteries, call toll free 1-800-822-8837, or visit <http://www.call2recycle.org>

⚠ WARNING: If a battery leak develops, avoid contact with the leaking acid and place the damaged battery in a plastic bag. Refer to the disposal instructions at left. If acid comes into contact with skin or eyes, flush with cool water for at least 15 minutes and contact a physician.

⚠ WARNING: Battery posts, terminals and related accessories contain lead and lead compounds. **Wash your hands after handling.**

Need Help? Visit our website for replacement parts, product support, a list of authorized service centers in the US and customer service contact information at www.razor.com. Please have the product I.D. code (located on the white label of your product) available for better assistance. Additional Customer Service contact information is listed at the back of this manual.

TROUBLESHOOTING GUIDE

*Product(s) should be turned **OFF** and fully charged prior to doing any Troubleshooting.

NOTE: All troubleshooting steps should be performed by an adult only.

Problem	Possible Cause	Solution
Does not work out of the box	Unit must be traveling at least 3 mph (5 km/h) before motor will engage	Kick to start to at least 3 mph (5 km/h) while engaging throttle to engage motor.
	Undercharged battery	Check lights on charger: Plugged into wall - Green Plugged into wall & unit - Red (charging) Plugged into wall & unit - Green (charging complete) No lights/Blinking lights - Replace charger
No longer works	No lights on charger	Check power to wall outlet and/or try a different outlet.
	Undercharged battery	Check lights on charger: Plugged into wall - Green Plugged into wall & unit - Red (charging) Plugged into wall & unit - Green (charging complete) No lights/Blinking lights - Replace charger
	Battery will not hold a charge	Replace battery.
Short run time/runs slow	Rider's weight	Do not exceed 220 lb (100 kg) maximum weight limit.
	Riding conditions	Use only on flat, dry surfaces. Avoid inclines and areas with heavy debris.
	Battery not fully charged	Charge product - refer to page 5 for charging information. Replace battery.
	Old/damaged battery	Charge battery at least once a month when not in use.

For more troubleshooting tips, a list of available replacement parts or to locate an authorized Service Center in your area, visit our website at www.razor.com or call toll free +1 866-467-2967 to speak to a live Customer Service Representative.

Need Help? Visit our website for replacement parts, product support, a list of authorized service centers in the US and customer service contact information at www.razor.com. Please have the product I.D. code (located on the white label of your product) available for better assistance. Additional Customer Service contact information is listed at the back of this manual.

FCC COMPLIANCE

This device complies with Part 15 of the FCC Rules. Operation is subject to the following two conditions: (1) This device may not cause harmful interference, and (2) this device must accept any interference received, including interference that may cause undesired operation.

Note: This equipment has been tested and found to comply with the limits for a Class B digital device, pursuant to part 15 of the FCC Rules. These limits are designed to provide reasonable protection against harmful interference in a residential installation. This equipment generates, uses and can radiate radio frequency energy and, if not installed and used in accordance with the instructions, may cause harmful interference to radio communications. However, there is no guarantee that interference will not occur in a particular installation. If this equipment does cause harmful interference to radio or television reception, which can be determined by turning the equipment off and on, the user is encouraged to try to correct the interference by one or more of the following measures:

- Reorient or relocate the receiving antenna.
- Increase the separation between the equipment and receiver.
- Connect the equipment into an outlet on a circuit different from that to which the receiver is connected.
- Consult the dealer or an experienced radio/TV technician for help.

⚠ WARNING: Changes or modifications to this unit not expressly approved by Razor USA, could void the user's authority to operate the equipment.

WARRANTY

Razor Limited Warranty

The manufacturer warrants this product to be free of manufacturing defects for a period of 90 days from date of purchase. This Limited Warranty does not cover normal wear and tear, tire, tube or cables, or any damage, failure or loss caused by improper assembly, maintenance, storage or use of the C25 SLA.

This Limited Warranty will be void if the product is ever:

- used in a manner other than for recreation or transportation;
- modified in any way;
- rented.

The manufacturer is not liable for incidental or consequential loss or damage due directly or indirectly to the use of this product.

Razor does not offer an extended warranty. If you have purchased an extended warranty, it must be honored by the store at which it was purchased.

For your records, save your original sales receipt with this manual and write the serial number below.

NOTICE: INSURANCE

YOUR INSURANCE POLICIES MAY NOT PROVIDE COVERAGE FOR ACCIDENTS INVOLVING THE USE OF THIS SCOOTER/ELECTRIC RIDE-ON PRODUCT. TO DETERMINE IF COVERAGE IS PROVIDED, YOU SHOULD CONTACT YOUR INSURANCE COMPANY OR AGENT.

CUSTOMER SERVICE CONTACT INFORMATION

Need Help? Visit our website for product support, a list of authorized service centers in the US and customer service contact information at www.razor.com. Please have the product I.D. code (located on the white label of your product) available for better assistance. Additional Customer Service contact information is listed below:

AMERICAS

Razor USA LLC
P.O. Box 3610
Cerritos, CA 90703
USA

+1 866 467 2967
Monday - Friday
8:00 AM - 5:00 PM Pacific Time
customersupport@razorusa.com

EUROPE, MIDDLE EAST, AFRICA

Razor USA LLC (Europe)
Handelsweg 2
2742 RD Waddinxveen
Netherlands

+44 (0) 120 267 2702
info@razoreu.com

ASIA

Razor USA LLC (Asia)
P.O. Box 3610
Cerritos, CA 90703
USA

+81 50 7579 6622
info@razor-asia.com

UNITED KINGDOM AND IRELAND

Razor USA LLC (UK)
Unit 20
Hartnoll Business Centre
Post Hill, Tiverton
Devon EX16 4NG
UK

+44 (0) 120 267 2702
info@razoreu.com

AUSTRALIA AND NEW ZEALAND:

Razor USA LLC
P.O. Box 4280
Auburn South
VIC 3122
Australia

+1 800 954 354 (AU)
+0 800 003 221 (NZ)
info@razoranz.com

IMPORTED IN JAPAN BY B-PLUS ASIA CORP.

Razor USA LLC
THE RIBSTIK COMPANY
Kurokawa 3-1, Asaoku,
Kawasaki, Kanagawa
215-0035 JAPAN

+81 (0) 44 328 9057 Tel
+81 (0) 44 328 9067 Fax
info@razor-asia.com

Printed in China for Razor USA LLC.

Copyright © 2003-2021 Razor USA, LLC. All rights reserved. Razor® and the Razor logo design are among the registered trademarks of Razor USA LLC in the United States and/or select foreign countries. C25™ and the C25 SLA logo design are trademarks of Razor USA LLC.