

**Required Tools: (Not included)**

- |                         |                 |
|-------------------------|-----------------|
| A. 5 mm Allen wrench    | C. 14 mm wrench |
| B. Phillips screwdriver | D. 17 mm wrench |

**⚠ WARNING**

**⚠ CAUTION:** To avoid potential shock or other injury, turn power switch **OFF** and disconnect charger before conducting any assembly or maintenance procedures. Failure to follow these steps in the correct order may cause irreparable damage.

**Step 1**

Using a 5 mm Allen wrench, loosen the two (2) bolts on the brake caliper and remove brake caliper from disc brake.

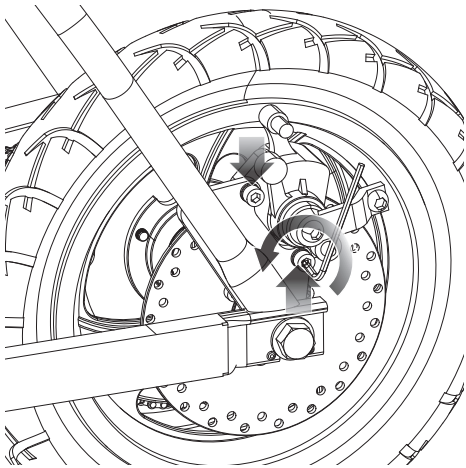
**Step 2**

Using a Phillips screwdriver, loosen the four (4) screws and remove chain guard.

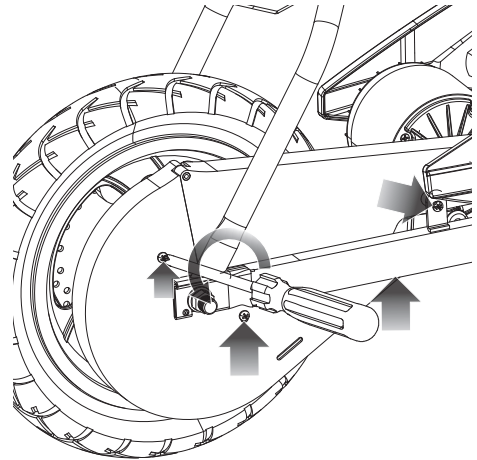

**Step 3**

Using a 14 mm and 17 mm wrench, loosen the locknut and axle bolt on the rear wheel.

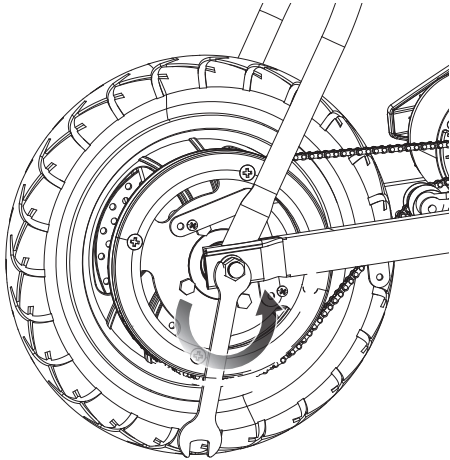
**Step 4**

Push the chain tensioner down to loosen the chain and remove the chain from the wheel sprocket and motor sprocket. Push wheel downward to remove.

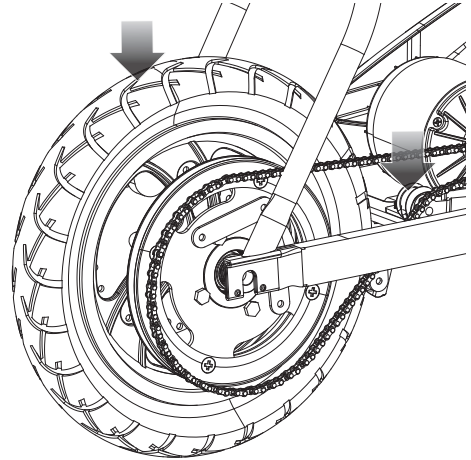
**Step 5**

Install the new chain or wheel by slipping the chain around the axle bolt. Slide the axle bolt into the slots on the frame. Slide the chain tensioner down and maneuver the chain onto the rear sprocket and motor sprocket.

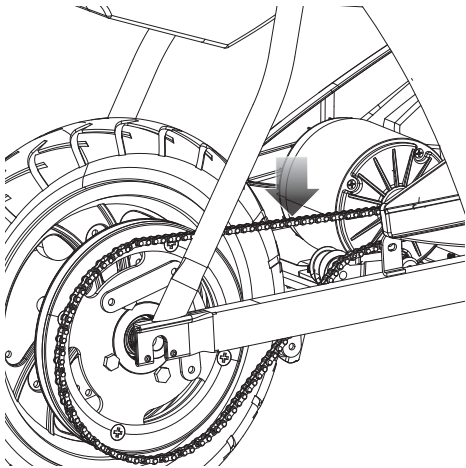

**⚠ WARNING:** To avoid a pinch or injury, keep fingers away from moving sprockets and chain.

**Step 6**

Re-attach the chain guard.

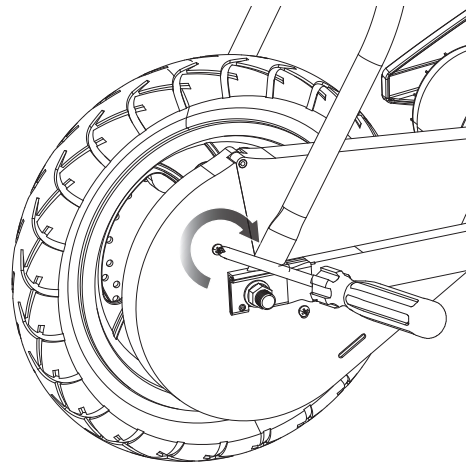

### Step 7

Re-attach the brake caliper to the disc brake and tighten securely in place with bolts removed in Step 1.

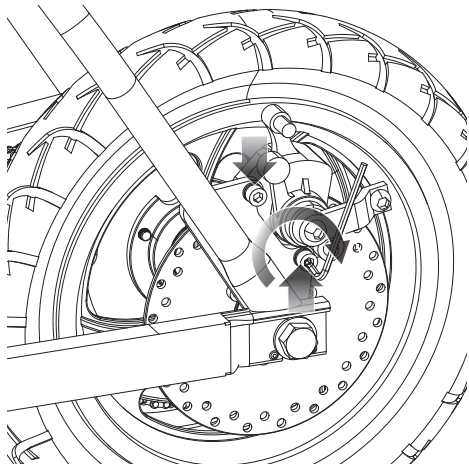

**⚠ WARNING:** Failing to properly adjust and tighten the nuts and bolts that affix the rear wheel can cause you to lose control and fall.

### Note

Note the hardware sequence (from outside toward the center).

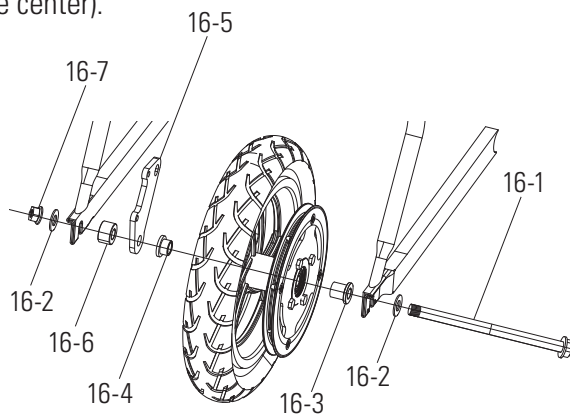

#### Left Side (Brake)

16-7 17 mm Locknut  
16-2 Flat Washer

#### Frame

16-6 Spacer  
16-5 Caliper Bracket  
16-4 Spacer (Small)

#### Right Side (Throttle)

16-3 Hat Spacer (Large)

#### Frame

16-2 Flat Washer  
16-1 Axle Bolt

**ATTENTION: Charge battery 12 hours before using.**