

Required Tools: (Not included)

A. 14 mm wrench

B. 17 mm wrench

⚠ WARNING

⚠ CAUTION: To avoid potential shock or other injury, turn power switch **OFF** and disconnect charger before conducting any assembly or maintenance procedures. Failure to follow these steps in the correct order may cause irreparable damage.

Using 14 mm and 17 mm wrench loosen the locknut; slide axle bolt out and remove front wheel. Insert the new wheel and tighten the locknut.

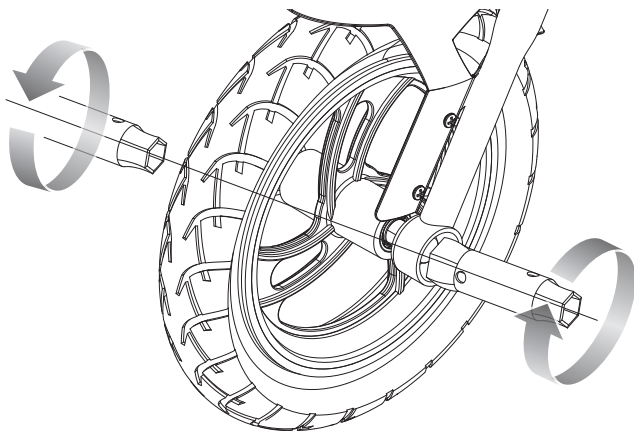

⚠ WARNING: Failing to properly adjust and tighten the nuts and bolts that affix the front wheel can cause you to lose control and fall.

Note the arrangement of the hardware sequence.

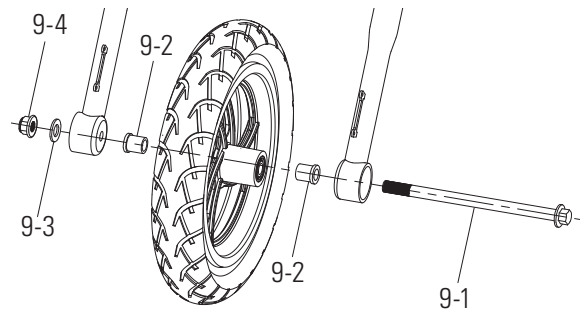

9-4 Locknut
9-3 Washer

Front Fork
9-2 Spacer

Wheel
9-2 Spacer

Front Fork
9-3 Washer
9-1 Axle Bolt

ATTENTION: Charge battery 12 hours before using.