

Required Tools: (Not included)

- A. Phillips screwdriver
- B. 14 mm wrench
- C. 17 mm wrench

⚠ WARNING

⚠ CAUTION: To avoid potential shock or other injury, turn power switch **OFF** and disconnect charger before conducting any assembly or maintenance procedures. Failure to follow these steps in the correct order may cause irreparable damage.

Step 1

Using a Phillips screwdriver, loosen the four (4) screws and remove chain guard.

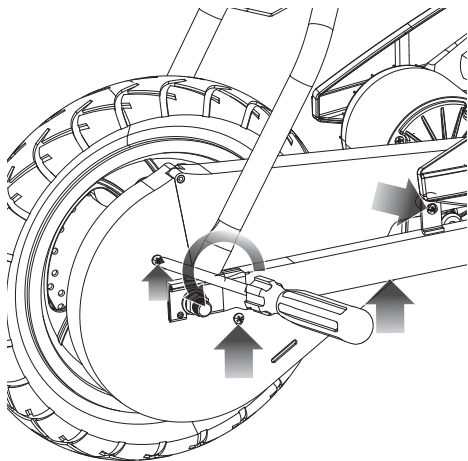
**Step 2**

Using a 14 mm and 17 mm wrench, loosen the locknut and axle bolt on the rear wheel.

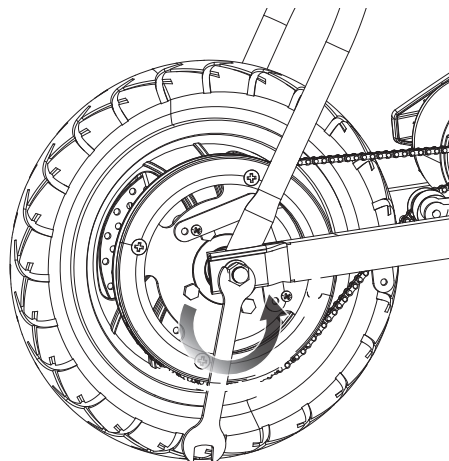

Step 3

Push the chain tensioner down to loosen the chain and remove the chain from the wheel sprocket and motor sprocket. Push wheel downward to remove.

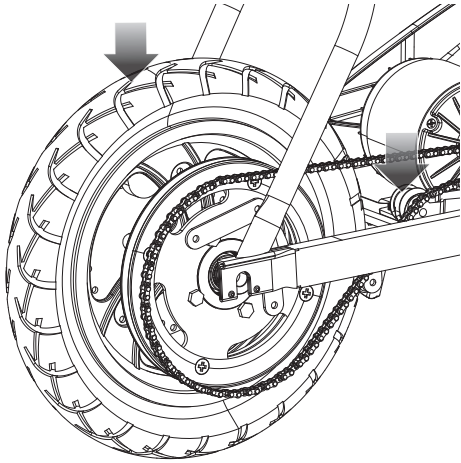
**Step 4**

Install the new chain or wheel by slipping the chain around the axle bolt. Slide the axle bolt into the slots on the frame. Slide the chain tensioner down and maneuver the chain onto the rear sprocket and motor sprocket.

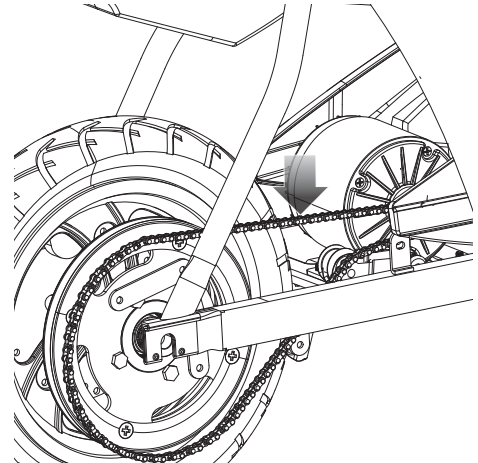
**Step 5**

Re-attach the chain guard.

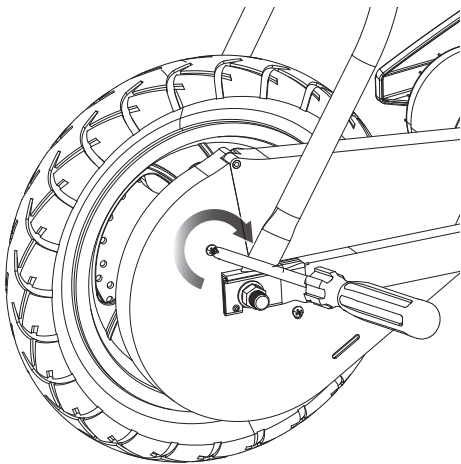

ATTENTION: Charge battery 12 hours before using.