

Required Tools: (Not included)

A. Phillips screwdriver

⚠ WARNING

⚠ CAUTION: To avoid potential shock or other injury, turn power switch **OFF** and disconnect charger before conducting any assembly or maintenance procedures. Failure to follow these steps in the correct order may cause irreparable damage.

Step 1

Using a Phillips screwdriver, loosen the four (4) screws and remove chain guard.

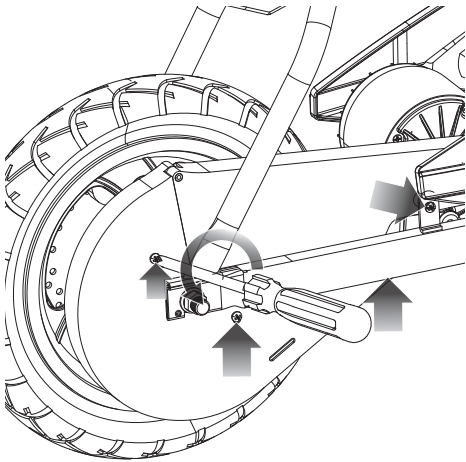
**Step 2**

Install the new chain guard using the four (4) screws.

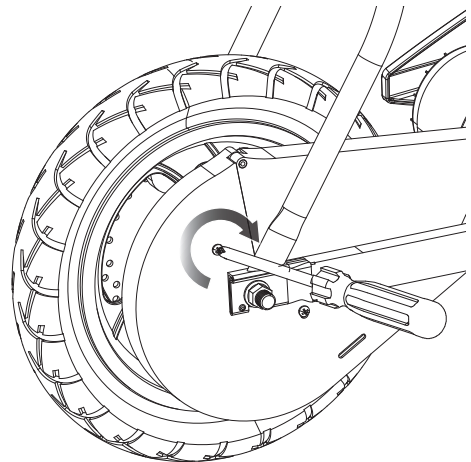

ATTENTION: Charge battery 12 hours before using.