



FLASH RIDER 360™

CASTER TRIKE



OWNER'S MANUAL

**Read and understand this entire manual before allowing child to use this product! For assistance contact Razor.
DO NOT RETURN TO STORE.**

**NOTE: Manual illustrations are for demonstration purposes only.
Illustrations may not reflect exact appearance of actual product.
Specifications subject to change without notice.**

**Please have your product along with the 22 character product I.D. code with you
before contacting Razor for warranty assistance and/or replacement parts.**

Product I.D. Code: _____ - _____ - _____

CONTENTS

Safety Warnings.....	1	Usage.....	5
Before You Begin.....	2	Repair and Maintenance.....	5
Assembly and Set-Up.....	3-4	Product Parts.....	6
Pre-Ride Checklist.....	4	Warranty and Contact Information.....	7

SAFETY WARNINGS

⚠ WARNING: SPARKS CAN INDUCE FIRE

To reduce the risk of **SERIOUS INJURY** or **FIRE**:

PARENTS and RIDERS: Make sure riders understand that sparks can start a fire. Keep sparks away from flammable or combustible substances. Use only under close adult supervision.

BE RESPONSIBLE: Safety is important. Parents must review the following warnings and instructions with each rider:

- Never use your caster trike to try to start a fire. Your caster trike emits localized sparks when the Spark Bar on a moving trike comes in contact with hardened outdoor surfaces, like asphalt or concrete. Be responsible.
- For outdoor use only on solid, clean, dry hardened surfaces. Keep sparks away from substances that can catch fire, such as dry vegetation, paper, chemicals or gasoline. Sparks can induce fire.
- Do not use in any area prone to wildfires or posted by fire authorities as a Fire Hazard Zone.
- Do not ride at night.
- Keep sparks away from eyes, hair, exposed skin and clothing. Sparks can burn.
- Pull up on the Spark Handle to operate sparking feature. NEVER push down directly on the Spark Bar, spark cartridge or cartridge cover itself.
- Spark Bar gets hot during use. Do not touch after use.

Observe all other spark safety warnings and instructions as provided elsewhere in this manual.

⚠ WARNING: Riding the FlashRider™ 360° Caster Trike can be a hazardous activity. Certain conditions may cause the equipment to fail without fault of the manufacturer. The FlashRider 360° Caster Trike can and is intended to move, and it is therefore possible to lose control, fall off and/or get into dangerous situations that no amount of care, instruction or expertise can eliminate. If such things occur you can be seriously injured or die, even when using safety equipment and other precautions. **RIDE AT YOUR OWN RISK AND USE COMMON SENSE.**

This manual contains many warnings and cautions concerning the consequences of failing to maintain, inspect or properly use your FlashRider 360° Caster Trike. Because any incident can result in serious injury or even death, we do not repeat the warning of potential serious injury or death each time such a possibility is mentioned.

APPROPRIATE RIDER USE AND PARENTAL SUPERVISION

This manual contains important safety information. It is your responsibility to review this information and make sure that all riders understand all warnings, cautions, instructions and safety topics, and assure that young riders are able to safely and responsibly use this product. Razor recommends that you periodically review and reinforce the information in this manual with younger riders, and that you inspect and maintain your child's FlashRider 360° to ensure their safety.

The recommended rider age of 6 and older for FlashRider 360° Caster Trike is only an estimate, and can be affected by the rider's size, weight or skills. Any rider unable to fit comfortably on the FlashRider 360° Caster Trike should not attempt to ride it. **A parent's decision to allow his or her child to ride this product should be based on the child's maturity, skill and ability to follow rules.**

Keep this product away from children under the age of 6 and remember that this product is intended for use only by persons who are, at a minimum, completely comfortable and competent while operating the FlashRider 360° and who understand the risks presented by such products.

DO NOT EXCEED THE WEIGHT LIMIT OF 160 LB (73 KG). Rider weight does not necessarily mean a person's size is appropriate to fit or maintain control of the FlashRider 360° Caster Trike.

ACCEPTABLE RIDING PRACTICES AND CONDITIONS

Always check and obey any local laws or regulations which may affect the locations where the FlashRider 360° Caster Trike may be used on public property. The FlashRider 360° Caster Trike is meant to be used only in controlled environments, free of potential traffic hazards and not on public streets. Do not ride your FlashRider 360° Caster Trike in any areas where pedestrian or vehicle traffic is present.

Ride defensively. Watch out for potential obstacles that could force you to swerve suddenly or lose control. Be careful to avoid pedestrians, skaters, skateboards, scooters, bikes, children or animals who may enter your path, and respect the rights and property of others.

Maintain a hold on the handlebars at all times.

Never carry passengers or allow more than one person at a time to ride the FlashRider 360° Caster Trike.

Never use near streets, swimming pools, hills, steps, or sloped driveways.

Never use headphones, a cell phone or text when riding.

Never hitch a ride with another vehicle.

The FlashRider 360° Caster Trike is intended for use on solid, flat, clean and dry surfaces, such as pavement or level ground, without loose debris, such as rocks or gravel. Wet, slick or uneven and rough surfaces may impair traction and contribute to possible accidents. Do not ride the FlashRider 360° Caster Trike in mud, ice, puddles or water. Avoid excessive speeds that can be associated with downhill rides. Never risk damaging surfaces, such as carpet or flooring, by use of a FlashRider 360° Caster Trike indoors.

Do not ride at night or when visibility is impaired.

PROPER RIDING ATTIRE

Riders should always wear an approved safety helmet. A helmet may be legally required by local law or regulation in your area. Elbow and kneepads, long sleeved shirt and long pants are recommended. Always wear closed toed shoes, keep shoelaces tied and out of the way of the wheels. Never ride barefooted or in sandals.

FAILURE TO USE COMMON SENSE AND HEED THE ABOVE WARNINGS INCREASES RISK OF SERIOUS INJURY. USE WITH APPROPRIATE CAUTION AND SERIOUS ATTENTION TO SAFE OPERATION.

BEFORE YOU BEGIN

Remove contents from box and check parts against parts diagram found on page 6. Remove the separators that protect the components from damage during shipping. Inspect the contents of the box for scratches in the paint or dents that may have occurred during shipping. Because the FlashRider 360° Caster Trike was partially assembled and packed at the factory there should not be any problems, even if the box has a few scars or dents.

Estimated Assembly and Set-Up Time

Allow up to 15-20 minutes for assembly.

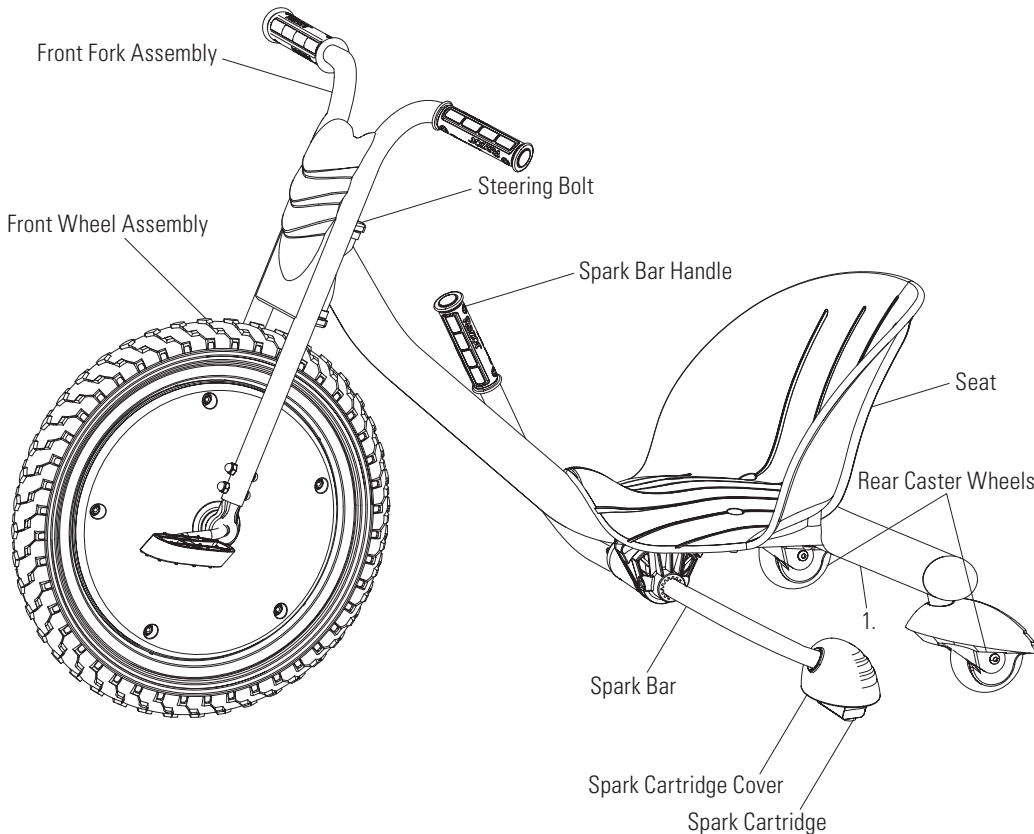

WARNING: DO NOT USE NON-RAZOR PRODUCTS WITH YOUR FLASHRIDER 360° CASTER TRIKE. The FlashRider 360° Caster Trike has been built to certain Razor design specifications. The original equipment supplied at the time of sale was selected on the basis of its compatibility with the frame, fork and all other parts. Certain aftermarket products may be compatible and will void your warranty.

Product ID Locations:

(See locations to the left)

1. Frame (underneath unit)
2. UPC Side of Box (not shown)

Required Tools

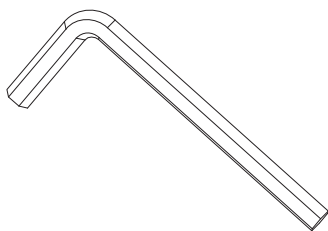

Two (2) 5 mm Allen Wrenches (Included)

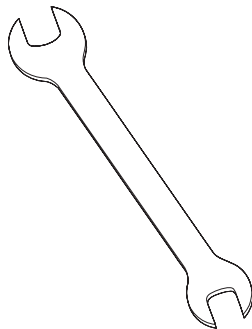

10 mm and 13 mm Wrenches (Included)

Plastic Bag Contents:

- Tools
- Owner's Manual

Need Help? Visit our website for replacement parts, product support, a list of authorized service centers in the US and customer service contact information at www.razor.com. Please have the product I.D. code (located on the white label of your product) available for better assistance. Additional Customer Service contact information is listed at the back of this manual.

ASSEMBLY AND SET-UP

□ Attaching the Frame

Required Tools: Two (2) 5 mm Allen Wrenches (included)

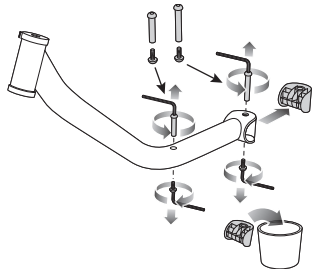

1 Using two (2) 5 mm Allen wrenches, remove the coupling bolt on the end of the frame and the coupling bolt in the middle of the frame. Remove and discard the plastic insert.

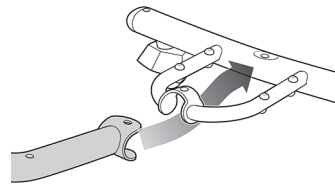

2 Insert the rear frame into the frame assembly.

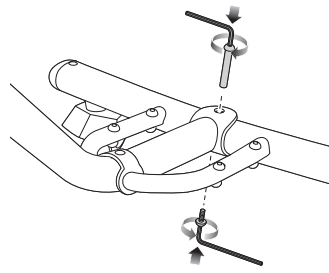

3 Securely tighten the (longer) coupling bolt on the rear frame using two (2) 5 mm Allen wrenches.

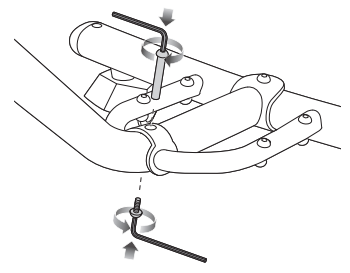

4 Securely tighten the (shorter) coupling bolt in the middle of the frame using two (2) 5 mm Allen wrenches.

Note: The coupling bolt in the middle of the frame is shorter.

□ Attaching the Spark Bar

Required Tools: 10 mm Wrench and 5 mm Allen Wrench (included)

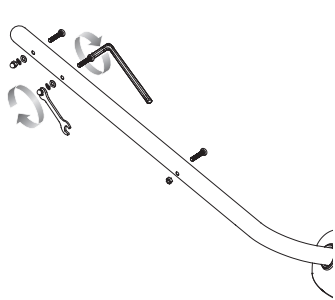

1 Using a 10 mm wrench and a 5 mm Allen wrench, remove the coupling bolts from the Spark Bar Handle.

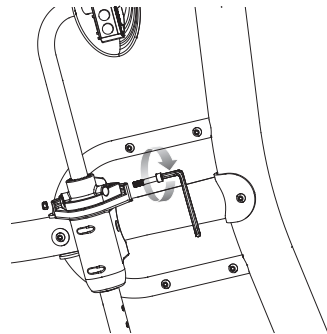

2 Insert the Spark Bar Handle (right side) and the Spark Bar (left side) into the spring mechanism. Align the holes on the Spark Bar Handle with the hole on the spring mechanism and tighten the coupling bolt with a 10 mm wrench and a 5 mm Allen wrench.

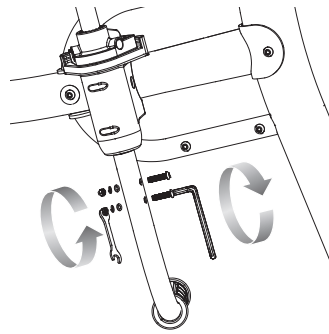

3 Align the holes on the Spark Bar Handle with the holes on the Spark Bar Handle and tighten the coupling bolts with a 10 mm wrench and a 5 mm Allen wrench.

□ Attaching the Front Fork

Required Tools: 13 mm Wrench and 5 mm Allen Wrench (included)

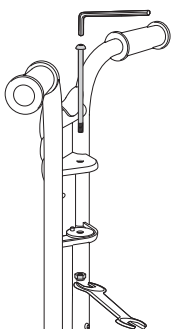

1 Remove the steering bolt and locknut from the frame assembly with a 13 mm wrench and a 5 mm Allen wrench.

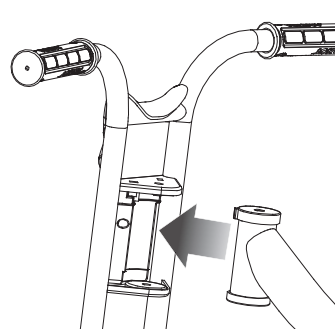

2 Insert the front fork into the frame assembly.

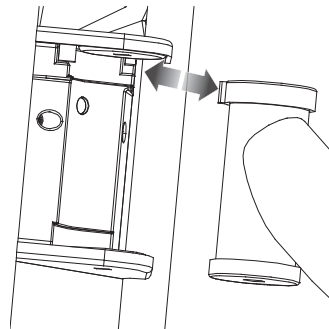

3 Be sure to properly align the slot on the headtube with the pin on the front fork as shown.

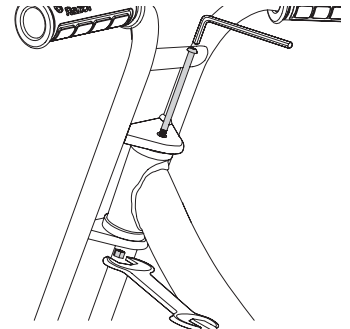

4 Reinsert the steering bolt and secure with locknut using a 13 mm wrench and a 5 mm Allen wrench.

⚠ WARNING: Failing to properly tighten the steering bolt that attaches the front fork assembly to the frame assembly can cause you to lose control and fall.

ASSEMBLY AND SET-UP

□ Attaching the Front Wheel

Required Tools: 5 mm Allen Wrench and 10 mm Wrench (included)

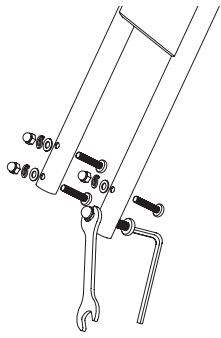

1 Remove the four (4) coupling bolts from the front fork using a 5 mm Allen wrench and a 10 mm wrench.

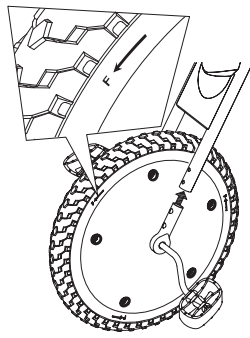

2 Insert the wheel assembly into the front fork and align holes. When installing the wheel, make sure the letter **"F"** and **arrow** (located on the side of the wheel) are facing the direction as shown above.

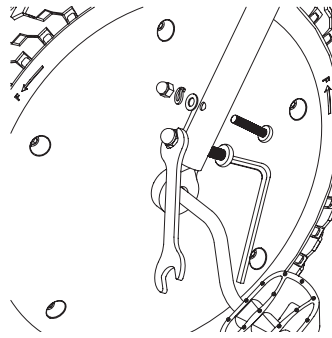

3 Reinsert the coupling bolts through the front fork and tighten securely.

□ Attaching the Seat

Required Tools: Two (2) 5 mm Allen Wrenches (included)

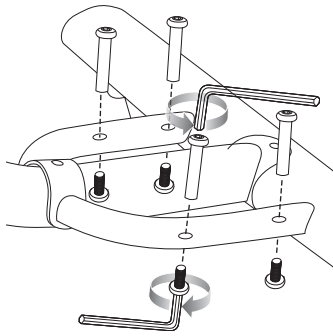

1 Using two (2) 5 mm Allen wrenches, remove the four (4) coupling bolts from the frame.

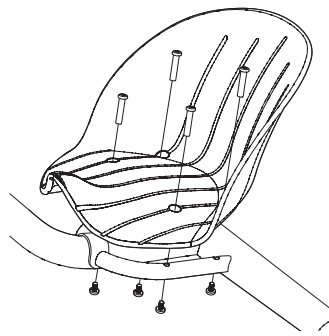

2 Align the four (4) holes in seat with the four (4) holes in frame. Insert the coupling bolts through the top and bottom of the frame.

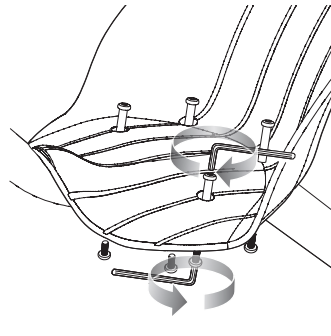

3 Tighten the coupling bolts using two (2) 5 mm Allen wrenches.

PRE-RIDE CHECKLIST



Wheels

Periodically inspect the wheels for excess wear.



Frame, Fork and Handlebars

Check for cracks or broken connections. Although broken frames are rare, it is possible for an aggressive rider to run into a curb or object and wreck and bend or break the frame. Get in the habit of inspecting your scooter on a regular basis.



Hardware/Loose Parts

Check and secure all fasteners before every ride. Make sure the steering bolt and casters are tight. There should not be any unusual rattles or sounds from loose parts or broken components. If the unit is damaged, do not ride. **Reference "Safety Warnings" on page 1 of this manual.**



Safety Gear

Always wear proper protective gear, such as an approved safety helmet. Elbow pads and kneepads are recommended. Always wear closed toe shoes (lace-up with rubber soles) and keep shoelaces tied and out of the way of the wheels. **NEVER RIDE BAREFOOTED OR IN SANDALS.**



Laws and Regulations

Always check and obey any local laws or regulations.



Be Careful!

This product is not for aggressive or trick riding. Avoid steep inclines and don't ride too fast — you can lose control and fall. Skateboard parks are not designed for young riders. Never ride in traffic or on the street and watch your surroundings for pedestrians, bikers, boarders and skaters.

Maintain a hold on the handlebars at all times.

Need Help? Visit our website for replacement parts, product support, a list of authorized service centers in the US and customer service contact information at www.razor.com. Please have the product I.D. code (located on the white label of your product) available for better assistance. Additional Customer Service contact information is listed at the back of this manual.

USAGE

□ Using the Spark Bar Handle

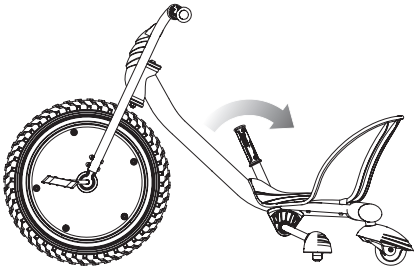

Pull back on the Spark Handle to operate sparking feature.

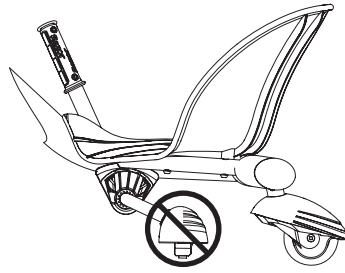

NEVER push down directly on the Spark Bar, Spark Cartridge or Spark Cartridge Cover itself.

⚠ WARNING: Pulling the Spark Bar Handle upwards too strenuously may cause loss of control.

NOTE: Sparks and Spark cartridge life will vary based on the amount of pressure applied by Spark Bar Handle, the length of time pressure is applied and the smoothness of the riding surface.

REPAIR AND MAINTENANCE

□ Cleaning

Wipe with a damp cloth to remove dirt and dust. Do not use industrial cleaners or solvents, as they may damage the surfaces. Do not use alcohol, alcohol-based or ammonia-based cleaners, as they may damage or dissolve the plastic components or soften the decals or decal adhesive.

□ Replacing the Spark Cartridge

Friction during sparking will eventually wear out the replaceable cartridge and cause the trike to stop making sparks. Worn out cartridges should be replaced.

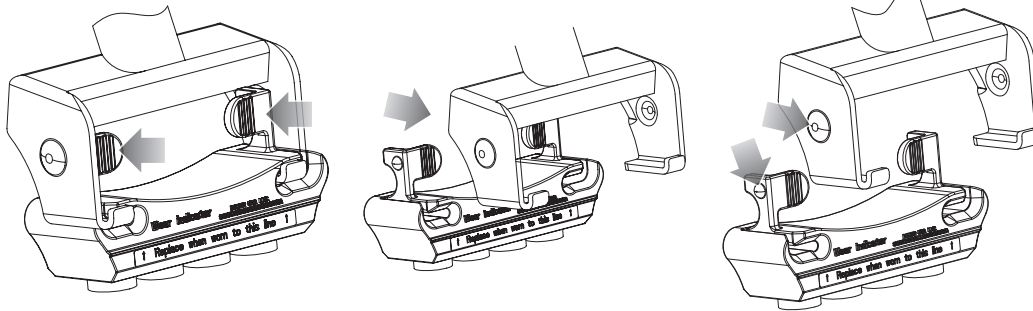

1 Using your thumbs, press tabs on both sides of the cartridge to release from the bracket. Slide the cartridge away from you and remove from bracket.

2 Place new cartridge in back of the bracket making sure to align the slots on the cartridge with the two legs of the bracket. Slide the cartridge forward until you hear a click and the thumb tabs are locked in place.

⚠ WARNING: Do not attempt to replace the cartridge immediately after riding as cartridge will be hot. Handle only when cool.

⚠ WARNING: Keep fingers clear of Spark Bar hinge.

□ Wheels and Bearings

Under normal circumstances and conditions, Razor wheels and wheel bearings are maintenance free. Nonetheless, it is the responsibility of the owner or guardian to periodically inspect the wheels for wear and tear, the axle for proper tightness, bearings for side-to-side play, and for loose parts. When a wheel develops play, this is an indication of excess wear and replacement is necessary. Replace immediately with only genuine Razor wheels. Worn wheels/bearings are considered normal wear-and-tear and are not covered by the Razor Warranty. Wheels other than genuine Razor wheels may not be compatible with your Razor scooter. The use of anything other than genuine Razor replacement parts may affect your safety and will void your warranty.

□ Replacement Parts

The most frequently requested replacement parts are available for purchase at some Razor retail partners. For the complete selection of replacement parts visit www.razor.com.

□ Repair Centers

For a list of authorized Razor repair centers:

- Check online at www.razor.com.
- Additional Customer Service contact information is listed at the back of this manual.

Need Help? Visit our website for replacement parts, product support, a list of authorized service centers in the US and customer service contact information at www.razor.com. Please have the product I.D. code (located on the white label of your product) available for better assistance. Additional Customer Service contact information is listed at the back of this manual.

PRODUCT PARTS

Keep your FlashRider 360° Caster Trike rolling for years with genuine Razor parts. Visit our website to purchase replacement parts. (Specifications subject to change without notice.)

- | | | |
|------------------------------------|---|------------------------------|
| 1. Handlebar Grip (x2) | 5. Front Wheel w/ Pedals and Cranks Complete | 7. Seat |
| 2. Front Fork | 6. Rear Wheel Complete (x2) | 7-1 Seat Coupling Bolts (x4) |
| 2-1 Front Fork Coupling Bolts (x4) | 6-1 Rear Wheel Covers (Right/Left)(Upper/Lower) | 8. Spark Bar Handle |
| 3. Front Cover | 6-2 Spring Washers (Right/Left) | 9. Spark Bar |
| 4. Steering Bolt | 6-3 Casters (Right/Left) | 10. Spark Cartridge |
| 4-1 Lock Nut | 6-4 Axle Bolts | 11. Spark Cartridge Cover |
| | 6-5 Wheels (Right/Left) | |

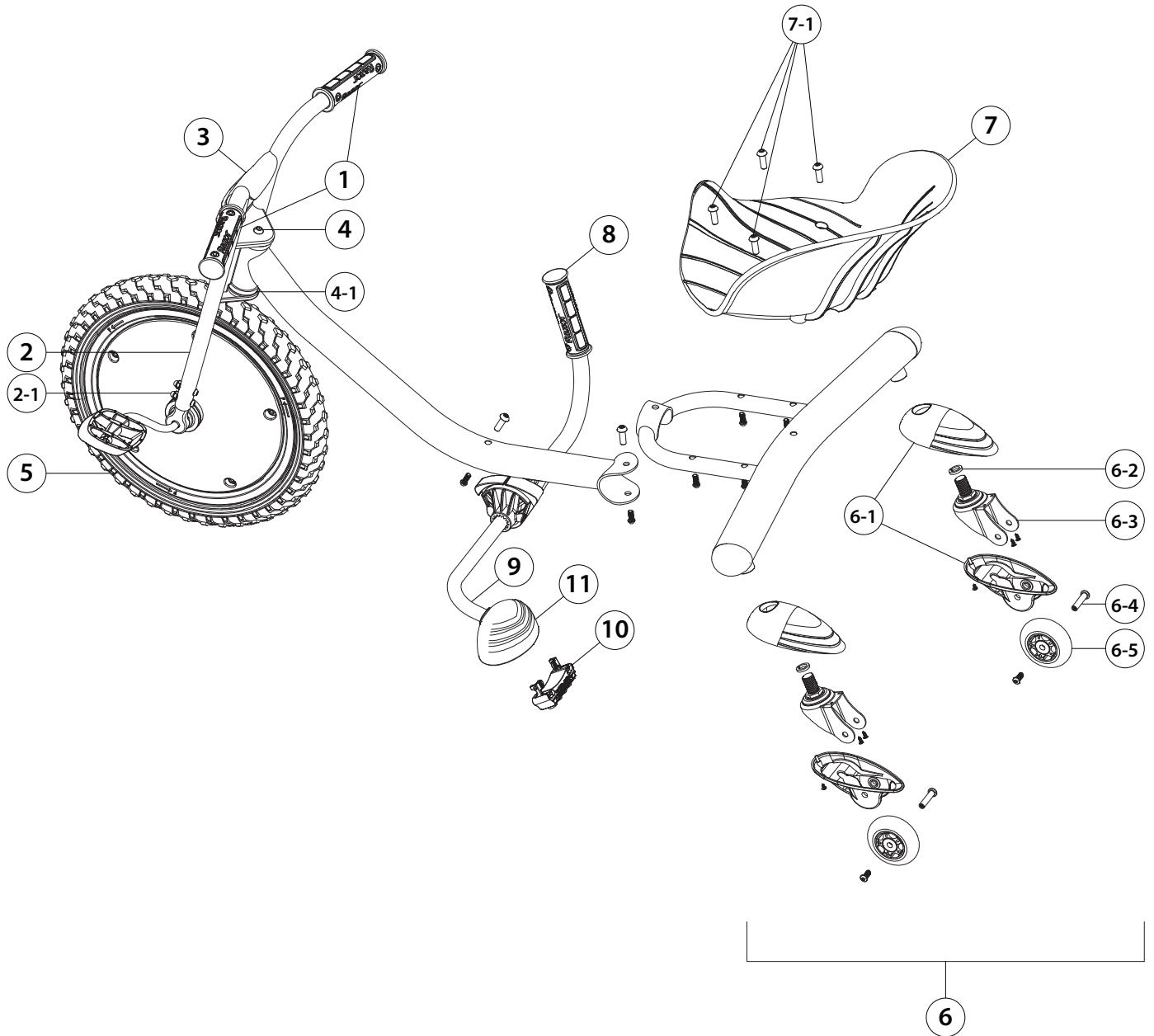

WARRANTY

Razor Limited Warranty

The manufacturer warrants this product to be free of manufacturing defects for a period of 6 months from date of purchase. This Limited Warranty does not cover normal wear and tear, or any damage, failure or loss caused by improper assembly, maintenance, or storage.

This Limited Warranty will be void if the product is ever:

- used in a manner other than for recreation or transportation;
- modified in any way
- rented.

The manufacturer is not liable for incidental or consequential loss or damage due directly or indirectly to the use of this product.

Razor does not offer an extended warranty. If you have purchased an extended warranty, it must be honored by the store at which it was purchased.

For your records, save your original sales receipt with this manual and write the serial number below.

CUSTOMER SERVICE CONTACT INFORMATION

Need Help? Visit our website for product support, a list of authorized service centers in the US and customer service contact information at www.razor.com. Please have the product I.D. code (located on the white label of your product) available for better assistance. Additional Customer Service contact information is listed below:

AMERICAS

Razor USA LLC
P.O. Box 3610
Cerritos, CA 90703
USA

+1 866 467 2967
Monday - Friday
8:00 AM - 5:00 PM Pacific Time
customersupport@razorusa.com

EUROPE, MIDDLE EAST, AFRICA

Razor USA LLC (Europe)
Handelsweg 2
2742 RD Waddinxveen
Netherlands

+44 (0) 120 267 2702
info@razoreu.com

ASIA

Razor USA LLC (Asia)
P.O. Box 3610
Cerritos, CA 90703
USA

+81 50 7579 6622
info@razor-asia.com

UNITED KINGDOM AND IRELAND

Razor USA LLC (UK)
Unit 20
Hartnoll Business Centre
Post Hill, Tiverton
Devon EX16 4NG
UK

+44 (0) 120 267 2702
info@razoreu.com

AUSTRALIA AND NEW ZEALAND

Razor USA LLC
P.O. Box 4280
Auburn South
VIC 3122
Australia

+1 800 954 354 (AU)
+0 800 003 221 (NZ)
info@razoranz.com

Printed in China for Razor USA LLC.

Copyright © 2003-2023 Razor USA, LLC. All rights reserved. Razor® and the Razor logo design are among the registered trademarks of Razor USA LLC in the United States and/or select foreign countries. FlashRider™ and the FlashRider logo design are trademarks of Razor USA LLC.