

Tools Required: (Not included)

- A. Phillips head screwdriver
- B. 2.5mm Allen wrench
- C. 5mm Allen wrench
- D. 10mm open wrench
- F. Flat head screwdriver

⚠ CAUTION: To avoid potential shock or other injury, turn power switch **OFF** and disconnect charger before attempting these procedures. Failure to follow these steps in the correct order may cause irreparable damage.

Step 1

Remove the two hex bolts under the seat using a 5mm Allen wrench and hold the nuts in the back using a 10mm open wrench

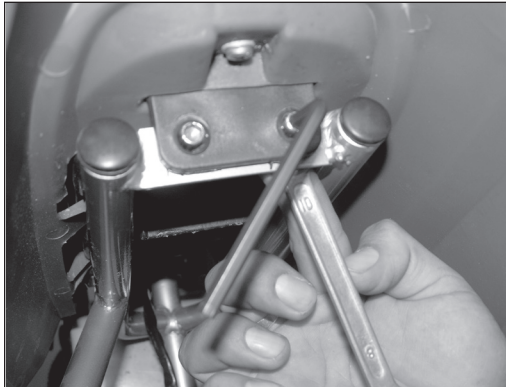

Figure 1

Step 2

Slide the fairing towards the back of the bike and remove.



Figure 2

Step 3

Remove the eight Phillip screws that hold the battery cover.

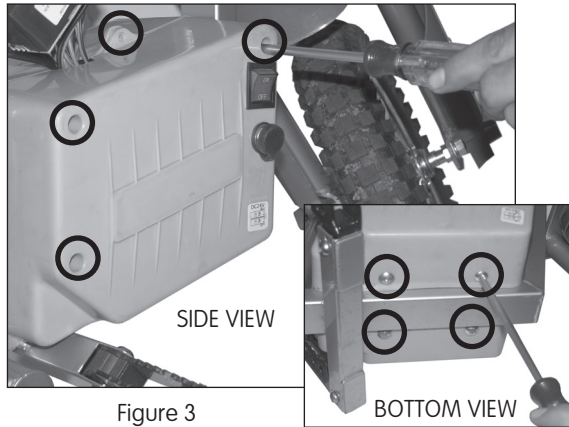

Figure 3

Step 4

Follow the throttle wire from the handlebars to locate the white plastic connector to the control module. Disconnect by depressing the tab. Cut the zip tie and remove the cable wrap. **Note:** Save the cable wrap for reassembly. Gently pull the throttle cable through the hole in the number plate.

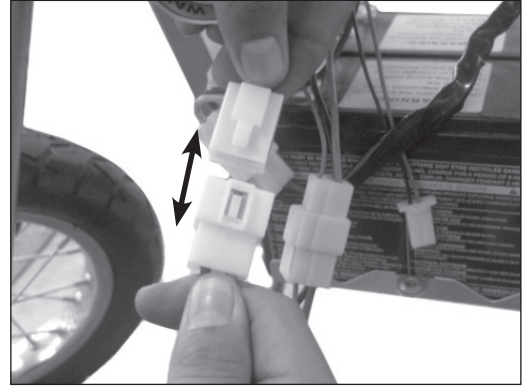

Figure 4

Step 5

Using a 2.5mm Allen wrench, loosen the throttle set screw, but do not remove and move throttle away from the grip.

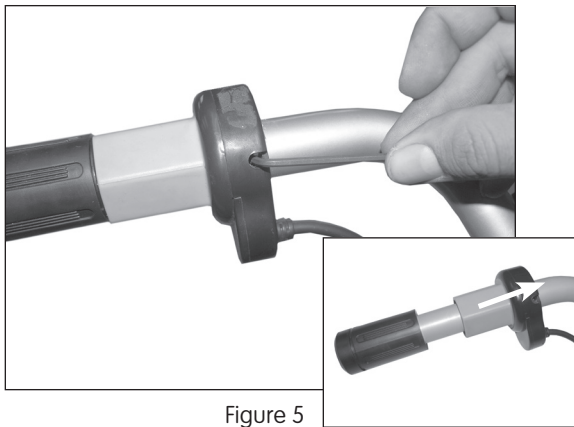

Figure 5

Step 6

Carefully wedge the flat head screwdriver under the edge of the handlebar grip add a small amount of lubricant or water and remove the grip. **Note:** Save the grip for reassembly



Figure 6

Step 7

Reverse steps:

1. Place the new throttle on handlebar and secure, cleaning the grip of any water or lubricant and reinstall.
2. Reconnect the white plastic throttle connector to that of the control module.
3. Reattach battery cover using the same eight screws previously removed.
4. Replace the fairing and refasten the screws.

ATTENTION: Charge unit at least 18 hours before riding.

130710