

Required Tools: (Not included)

A. Phillips screwdriver

B. 8 mm wrench

C. 10 mm wrench

D. Two (2) 15 mm wrenches

⚠WARNING

⚠CAUTION: To avoid potential shock or other injury, turn power switch OFF and disconnect charger before performing any assembly or maintenance procedures. Failure to follow these steps in the correct order may cause irreparable damage.

Step 1

Using a Phillips screwdriver loosen the screws on chain guard and remove the chain guard.

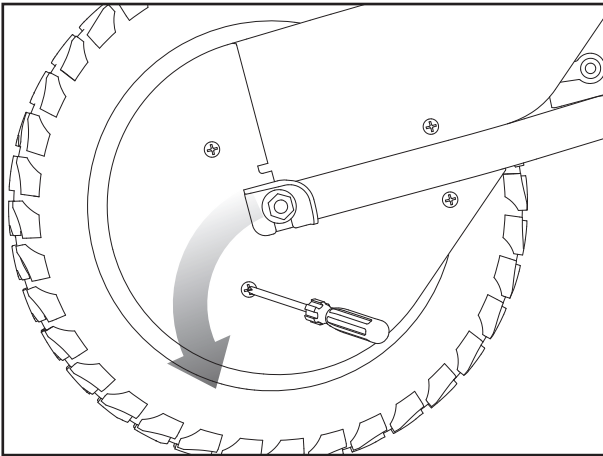
**Step 2**

With a 10 mm wrench, loosen the brake cable anchor bolt and disconnect the cable.

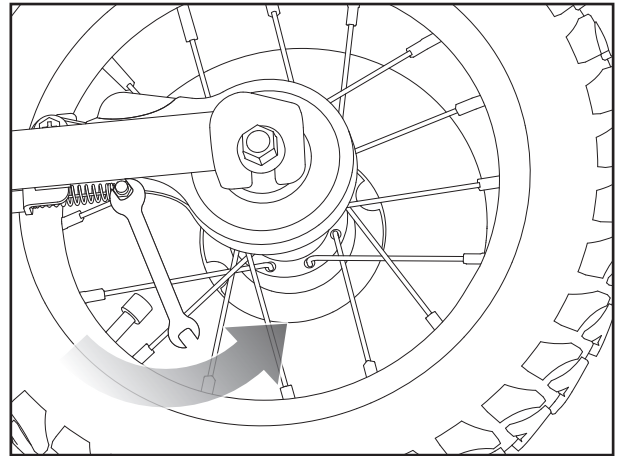

Step 3

With a Phillips screwdriver and 8 mm wrench remove the cable guide bracket from the frame and brake plate. Keep the spacer and washers together.

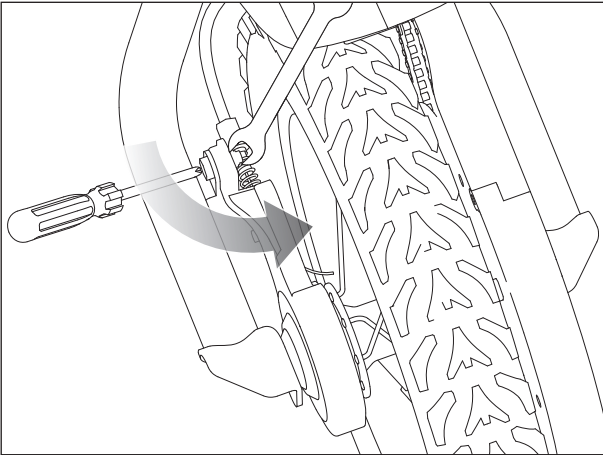
**Step 4**

With two (2) 15 mm wrenches, loosen the locknuts. Push the chain tensioner down to loosen the chain and remove wheel.

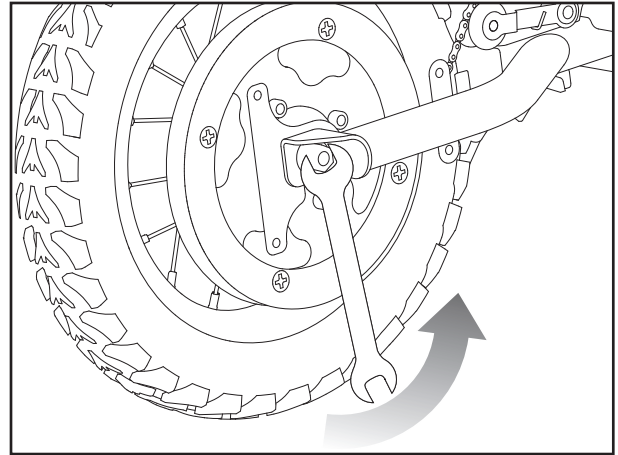
**Step 5**

Install the chain onto the rear wheel sprocket. Slip wheel axle into the frame slots. Push the chain tensioner down to create slack in chain. Hand tighten rear axle locknuts.

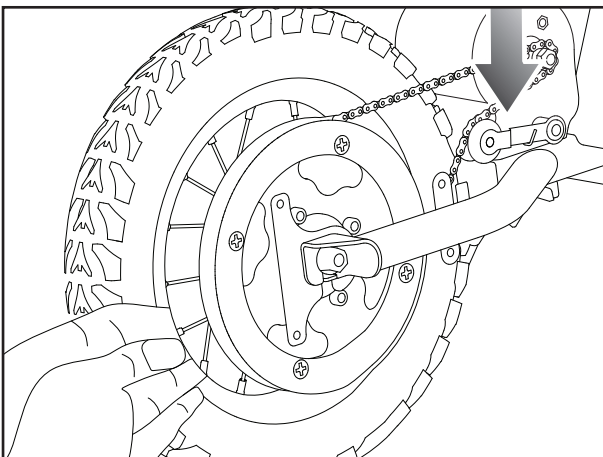
**Step 6**

Verify chain is properly installed on each sprocket and tensioner is correctly positioned at the bottom of the chain.

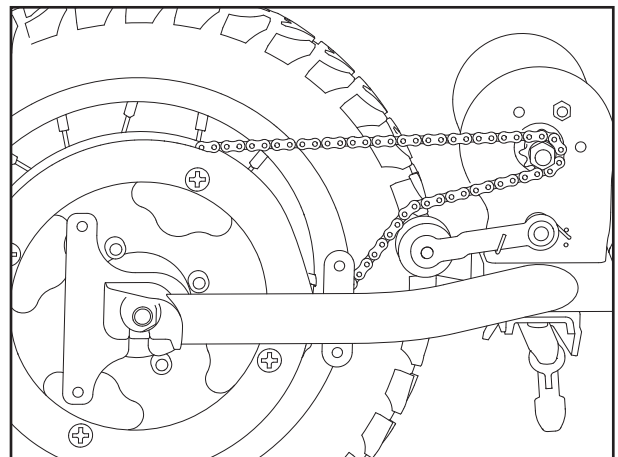

Step 7

Using a Phillips screwdriver, screw chain guard back in place.

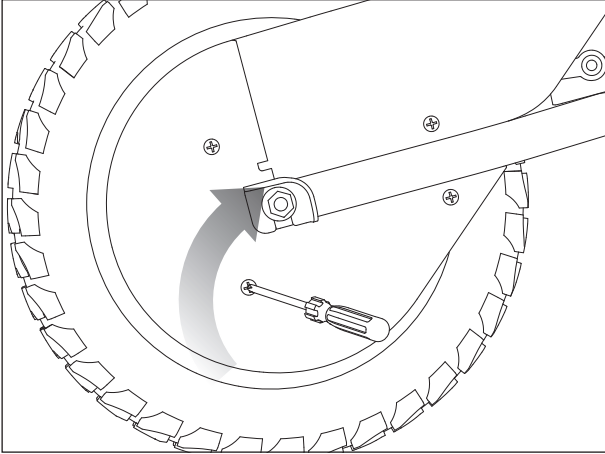
**Step 8**

Install the cable guide bracket to the frame and brake plate using bolt, washers, and nut. Do not tighten.

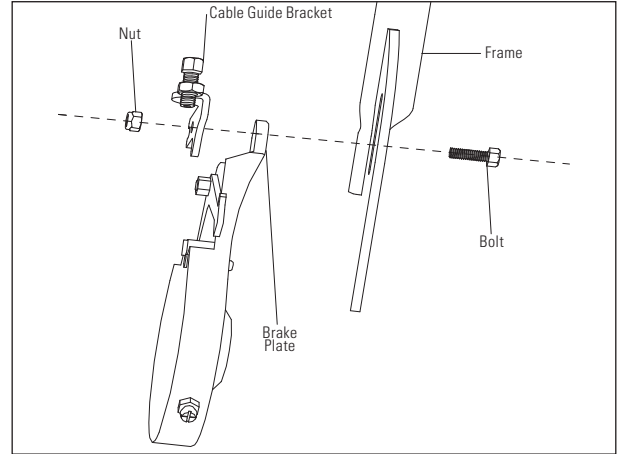
**Step 9**

Thread the brake cable through the brake adjuster barrel, through the large spring, and into the small hole in the side of the anchor bolt. Position the cable to the original location (as indicated by the slight cable kink) and tighten securely.

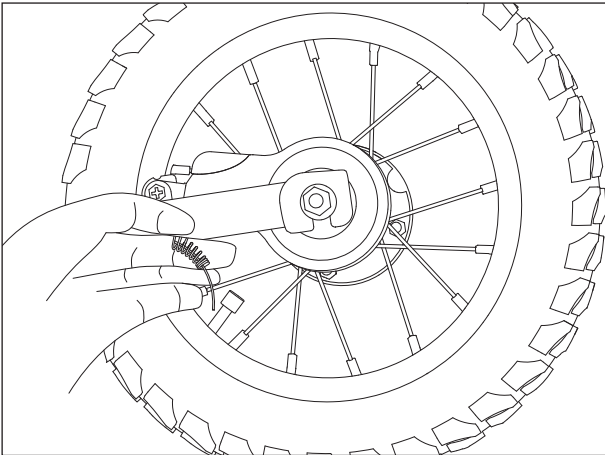
**Step 10**

Tighten the cable guide bracket bolt. Tighten the locknuts on the rear axle. Test the brake to verify proper function before riding. Readjust as needed.

