



## HOVERTRAX™ 2.0 REPLACEMENT BATTERY PACK KIT



# OWNER'S MANUAL

**Read and understand this entire manual before using this product! For assistance contact Razor.**

**DO NOT RETURN TO STORE.**

NOTE: Manual illustrations are for demonstration purposes only. Illustrations may not reflect exact appearance of actual product. Specifications subject to change without notice.

Please have your product along with the 19 character product I.D. code with you before contacting Razor for warranty assistance and/or replacement parts.

Product I.D. Code: \_\_\_\_\_ - \_\_\_\_\_ - \_\_\_\_\_

# CONTENTS

Set Up.....	1
Charging the Battery.....	2-3
Repair and Maintenance.....	3-4
Warranty.....	5
Customer Service Contact Information.....	7

## Box Contents:

- Hovertrax 2.0 Battery Pack
- Charging Dock
- Owner's Manual

## USE ONLY WITH RAZOR HOVERTRAX 2.0 CHARGER (NOT INCLUDED)

# SET UP

**1** Remove the battery and dock from box.

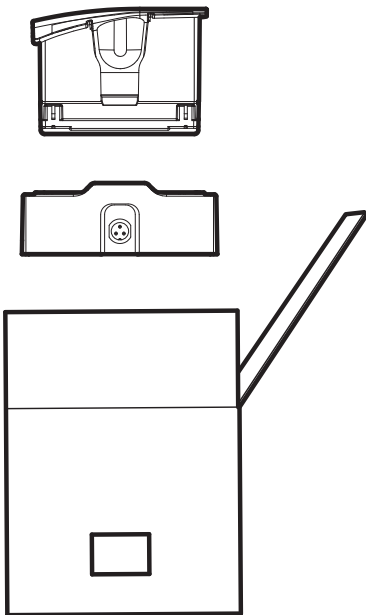

**2** Set battery in dock.

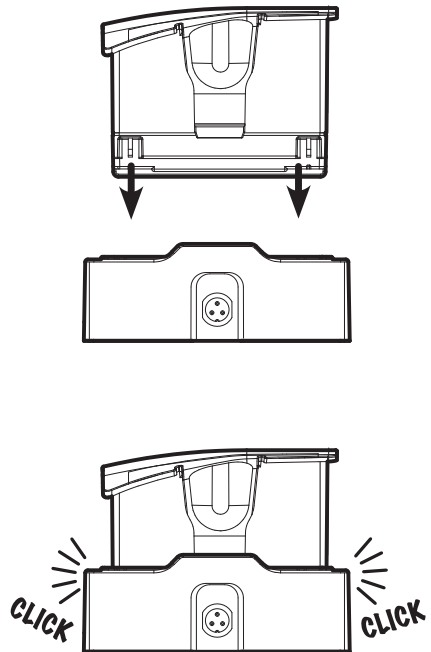

**Need Help?** Visit our website for replacement parts, product support, a list of authorized service centers in the US and customer service contact information at [www.razor.com](http://www.razor.com). Please have the product I.D. code (located on the white label of your product) available for better assistance. Additional Customer Service contact information is listed at the back of this manual.

# CHARGING THE BATTERY

Your Hovertrax 2.0 replacement battery may not be fully charged; therefore you must charge the battery prior to use. Be sure to charge the battery in a clean, dry location away from direct sunlight, flames or sparks.

- Use only Razor Hovertrax 2.0 charger (not included).
- Initial charge time: 6 hours.
- Recharge time: up to 6 hours, even if the light turns green. Recommended maximum charging time is 24 hours.
- Always charge the battery immediately after riding.
- Fully charge battery before storing for extended periods of time.
- Unplug charger from the wall outlet when not in use.
- Failure to recharge battery periodically may result in a battery that will not accept a charge.
- Do not charge at or below 32° F (0° C).

(Note: Charger design may vary from one shown)

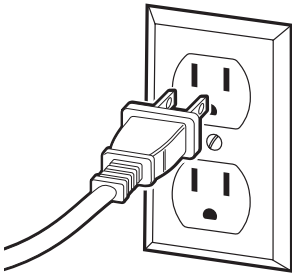
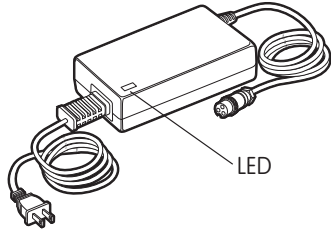

**1** Plug the charger plug into wall outlet. The light on the charger should be green.

Note: If green light (LED) does not turn on, try a different outlet.

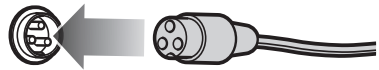

**2** Plug the charger into the charger port on the charging dock. The light on the charger should turn red during charging. The light will turn green again when charging is complete.

- Do not allow charger, dock or battery to overheat. If they seem warm, allow to cool down. Charge only at room temperature.
- Do not place charger, dock or battery in the sun or warm environment. Keep at normal room temperature.

Model	Voltage (Nominal) Vdc	Capacity (Nominal) Ah	Charge Temperature Range	Operating Temperature Range
Hovertrax 2.0	36	2.4	0° to 40°C 32° to 104°F	-10° to 40°C 14° to 104°F

## CHARGING THE BATTERY

### **WARNING:**

Use **ONLY** with the recommended charger. Battery is only to be charged under adult supervision. The charger is not a toy. Always disconnect the charger before wiping down and/or cleaning the Hovertrax 2.0 with a damp cloth.

The charger supplied with your Hovertrax 2.0 should be regularly examined for damage to the cord, plug, enclosure and other parts. In the event of such damage, the Hovertrax 2.0 battery must not be charged until charger has been repaired or replaced.

Chargers have built-in overcharge protection to prevent battery from being overcharged.

Wall outlet - Green (stand by)

Wall outlet and product - Red (charging)

Wall outlet and product - Green (charged)

Note: Continue charging battery even if light turns green prior to 6 hours.

### **WARNING:**

Failure to recharge the battery at least once a month may result in a battery that will no longer accept a charge.

## REPAIR AND MAINTENANCE

### **WARNING:** Risk of fire—no user serviceable parts.

### **Battery Care and Disposal**

Do not store in freezing or below freezing temperatures. To properly maintain your battery and ensure maximum battery life, carefully read the “Charging the Battery” section on pages 2-3 of this owner’s manual.



CONTAINS LITHIUM-ION BATTERY PACK. BATTERIES MUST BE RECYCLED.  
UL 2271 COMPLIANT.

**Disposal:** Your Razor Hovertrax 2.0 uses a lithium-ion battery pack which must be recycled or disposed of in an environmentally safe manner. Do not dispose of a battery pack in a fire. The battery pack may explode. Do not dispose of a battery pack in your regular household trash. The incineration, land filling or mixing of batteries with household trash is prohibited by law in most areas. Return exhausted batteries to a federal or state approved lithium-ion battery recycler.

---

**Need Help?** Visit our website for replacement parts, product support, a list of authorized service centers in the US and customer service contact information at [www.razor.com](http://www.razor.com). Please have the product I.D. code (located on the white label of your product) available for better assistance. Additional Customer Service contact information is listed at the back of this manual.

# REPAIR AND MAINTENANCE



## Recycling Lithium-Ion Batteries:

Lithium-ion batteries are recyclable. You can help preserve our environment by returning your used rechargeable batteries to the collection and recycling location nearest you.

## In the US and Canada only:

For more information regarding recycling of rechargeable batteries, call toll free 1-800-822-8837, or visit <http://www.call2recycle.org>

**Caution:** Do not handle damaged lithium-ion batteries.



**Take batteries to a certified recycling or disposal center.** (See page 3 for information on how to properly dispose of lithium-ion batteries)

**Recycling Lithium-ion Batteries:** Lithium-ion batteries are recyclable. You can help preserve our environment by returning your used rechargeable batteries to the collection and recycling location nearest you.

**Caution:** Do not handle damaged lithium-ion batteries.

Lithium-ion batteries contain toxic materials. All toxic materials must be recycled or disposed of in a specified manner to prevent contamination of the environment. Before disposing of any lithium-ion batteries, contact your local waste disposal agency or a local Environmental Protection Agency office, certified for lithium-ion disposal, for information and specific instructions.

To avoid injury and risk of fire, explosion, or electric shock, and to avoid damage to the environment:

- DO NOT attempt to open the battery pack.
- DO NOT attempt to remove or destroy any of the battery pack components.
- DO NOT place batteries in your regular household trash.
- DO NOT incinerate.
- DO NOT place batteries where they will become part any waste landfill or municipal solid waste stream.

## WARRANTY

### Razor Limited Warranty

The manufacturer warrants this product to be free of manufacturing defects for a period of 90 days from date of purchase. This Limited Warranty does not cover normal wear and tear, tires, tubes or cables, or any damage, failure or loss caused by improper assembly, maintenance, storage or use of the Razor Hovertrax 2.0.

This Limited Warranty will be void if the product is ever:

- used in a manner other than for recreation or transportation;
- modified in any way;
- rented.

The manufacturer is not liable for incidental or consequential loss or damage due directly or indirectly to the use of this product.

Razor does not offer an extended warranty. If you have purchased an extended warranty, it must be honored by the store at which it was purchased.

For your records, save your original sales receipt with this manual and write the serial number below.

---

## FCC COMPLIANCE

This device complies with Part 15 of the FCC Rules. Operation is subject to the following two conditions: (1) This device may not cause harmful interference, and (2) this device must accept any interference received, including interference that may cause undesired operation.

Note: This equipment has been tested and found to comply with the limits for a Class B digital device, pursuant to part 15 of the FCC Rules. These limits are designed to provide reasonable protection against harmful interference in a residential installation. This equipment generates, uses and can radiate radio frequency energy and, if not installed and used in accordance with the instructions, may cause harmful interference to radio communications. However, there is no guarantee that interference will not occur in a particular installation. If this equipment does cause harmful interference to radio or television reception, which can be determined by turning the equipment off and on, the user is encouraged to try to correct the interference by one or more of the following measures:

- Reorient or relocate the receiving antenna.
- Increase the separation between the equipment and receiver.
- Connect the equipment into an outlet on a circuit different from that to which the receiver is connected.
- Consult the dealer or an experienced radio/TV technician for help.

**⚠ WARNING:** Changes or modifications to this unit not expressly approved by Razor USA LLC, could void the user's authority to operate the equipment.

---

**Need Help?** Visit our website for replacement parts, product support, a list of authorized service centers in the US and customer service contact information at [www.razor.com](http://www.razor.com). Please have the product I.D. code (located on the white label of your product) available for better assistance. Additional Customer Service contact information is listed at the back of this manual.



## CUSTOMER SERVICE CONTACT INFORMATION

**Need Help?** Visit our website for product support, a list of authorized service centers in the US and customer service contact information at [www.razor.com](http://www.razor.com). Please have the product I.D. code (located on the white label of your product) available for better assistance. Additional Customer Service contact information is listed below:

### AMERICAS

Razor USA LLC  
P.O. Box 3610  
Cerritos, CA 90703  
USA

+1 866 467 2967  
Monday - Friday  
8:00 AM - 5:00 PM Pacific Time  
[customersupport@razorusa.com](mailto:customersupport@razorusa.com)

### EUROPE, MIDDLE EAST, AFRICA

Razor USA LLC (Europe)  
Handelsweg 2  
2742 RD Waddinxveen  
Netherlands

+44 (0) 120 267 2702  
[info@razoreu.com](mailto:info@razoreu.com)

### ASIA

Razor USA LLC (Asia)  
P.O. Box 3610  
Cerritos, CA 90703  
USA

+81 50 7579 6622  
[info@razor-asia.com](mailto:info@razor-asia.com)

### UNITED KINGDOM AND IRELAND

Razor USA LLC (UK)  
Unit 20  
Hartnoll Business Centre  
Post Hill, Tiverton  
Devon EX16 4NG  
UK

+44 (0) 120 267 2702  
[info@razoreu.com](mailto:info@razoreu.com)

### DISTRIBUTED IN AUSTRALIA BY:

Funtastic Limited  
Suite 2.01, Level 2  
315 Ferntree Gully Road  
Mount Waverley Vic 3149,  
Australia

+1 800 244 543  
[info@funtastic.com.au](mailto:info@funtastic.com.au)