



DIRT QUAD

YOUTH SPORT ELECTRIC OFF-ROAD QUAD



OWNER'S MANUAL

Read and understand this entire manual before allowing child to use this product! For assistance contact Razor. DO NOT RETURN TO STORE.

NOTE: Manual illustrations are for demonstration purposes only. Illustrations may not reflect exact appearance of actual product. Specifications subject to change without notice.

Please have your product along with the 19 character product I.D. code with you before contacting Razor for warranty assistance and/or replacement parts.

Product I.D. Code: _____ - _____ - _____

CONTENTS

Safety Warnings.....	1-2	Repair and Maintenance.....	8-10
Before You Begin.....	3	Troubleshooting Guide	11
Assembly and Set-Up.....	4-5	Dirt Quad Parts.....	12
Charging the Battery/Pre-Ride Checklist.....	6	Warranty and Contact Information	14
Usage	7		

SAFETY WARNINGS

⚠ WARNING: Riding a four-wheeled electric product like the the Dirt Quad does present potential risks and caution is required. Like any riding product, the Dirt Quad has inherent hazards associated with its use (for example, falling off or riding it into a hazardous situation). Like any riding product, Dirt Quads can and are intended to move, and it is therefore possible to lose control or otherwise get into dangerous situations. Both children and adults responsible for supervising them must recognize that if such things occur, a rider can be seriously injured or die, even when using safety equipment and other precautions. **RIDE AT YOUR OWN RISK AND USE COMMON SENSE.**

⚠ WARNING: PARENTAL AND ADULT RESPONSIBILITY AND SUPERVISION IS NECESSARY: Because products like this product, can and do present potential hazards plainly associated with their use, it is well recognized THE NEED FOR EXERCISE OF PARENTAL RESPONSIBILITY IN SELECTING RIDING PRODUCTS APPROPRIATE TO THE AGE OF A CHILD, OR PARENTAL SUPERVISION IN SITUATIONS IN WHICH CHILDREN OF VARIOUS AGES MAY HAVE ACCESS TO THE SAME RIDING PRODUCTS, IS IMPORTANT. Not every product is appropriate for every age or size of child, and different age recommendations are found within this category of product which are intended to reflect the nature of the hazards and the expected mental or physical ability, or both, of a child to cope with the hazards.

⚠ WARNING: PARENT CONTROLLED HIGH/LOW SPEED SWITCH: The Dirt Quad has a HIGH-LOW speed switch which can be manually set by an adult before children ride it. This switch allows parents to reduce the Dirt Quad speed for novice riders. See page 5. The default setting is HIGH.

The recommended minimum rider age is 8 and older. Any rider unable to fit comfortably on the Dirt Quad should not attempt to ride it. A parent's decision to allow his or her child to ride this product should be based on the child's maturity, skill and ability to follow rules. **Do not allow children under eight (8) years old to ride the Dirt Quad.**

Keep this product away from small children and remember that this product is intended for use only by persons who are, at a minimum, completely comfortable and competent while operating the product.

Persons with any mental or physical conditions that may make them susceptible to injury, impair their physical dexterity or mental capabilities to recognize, understand, and follow safety instructions and to be able to understand the hazards, should not use or be permitted to use products inappropriate for their abilities. Persons with heart conditions, head, back or neck ailments (or prior surgeries to these areas of the body), or pregnant women, should be cautioned not to operate such products.

DO NOT EXCEED THE WEIGHT LIMIT OF 120 lb (54 kg). Rider weight does not necessarily mean a person's size is appropriate to fit or maintain control of the Dirt Quad.

CHECK AND MAINTAIN PRODUCT CONDITIONS

Before use, check to confirm that any and all chain guards or other covers and guards are in place and in serviceable condition. Check that the brake is functioning properly, and that tires are inflated properly and have sufficient tread remaining. The product should be maintained and repaired in accordance with the manufacturer's specifications, using only the manufacturer's authorized replacement parts, and should not be modified from the manufacturer's original design and configuration.

ACCEPTABLE RIDING PRACTICES AND CONDITIONS

Always check and obey any local laws or regulations which may affect the locations where the Dirt Quad may be used.

Ride defensively. Watch out for potential obstacles that could catch your wheel(s) or force you to swerve suddenly or lose control. Be careful to avoid pedestrians, skaters, skateboards, scooters, bikes, children or animals who may enter your path, and respect the rights and property of others.

The Dirt Quad is meant to be used on private property and on closed courses and not on public streets or sidewalks. Do not ride your electric four wheeler in any areas where pedestrian or vehicle traffic are present.

Do not activate the speed control on the hand grip unless you are on the electric four wheeler and in a safe, outdoor environment suitable for riding.

The normal (factory set) powered top speed of this product will be approximately 8 mph (13 km/h) and the parent controlled HIGH-LOW speed switch can be set to a lower speed of 5 mph (8 km/h), which can be affected by conditions, such as rider weight, inclines and battery charge level. Avoid excessive speeds that can be associated with downhill rides.

This product was manufactured for performance and durability, but is not impervious to damage. Jumping or other aggressive riding can overstress and damage any product, including the Dirt Quad, and the rider assumes all risks associated with high-stress activity.

Be careful and know your limitations. Risk of injury increases as the degree of riding difficulty increases. The rider assumes all risk associated with aggressive riding activities.

Maintain a hold on the handlebars at all times.

Never carry passengers or allow more than one person at a time to ride the electric four wheeler.

Never use near steps or swimming pools.

Do not allow hands, feet, hair, body parts, clothing, or similar articles, to come in contact with moving parts of the Dirt Quad, including the brake, wheels or drive train, while the motor is on. Do not touch the brake or electric motor on your electric four wheeler when in use and/or immediately after riding, as they can become very hot.

Never use headphones or a cell phone to talk or text when riding.

Never hitch a ride with another product or vehicle.

Do not ride the Dirt Quad in wet or icy weather and never immerse the electric four wheeler in water, as the electrical and drive components could be damaged by water or create other possible unsafe conditions.

Wet, slick, bumpy, uneven or rough surfaces may increase risks of use. Do not ride the electric four wheeler in mud, ice, puddles or water. Avoid excessive speeds that can be associated with downhill rides. Never risk damaging surfaces, such as carpet or flooring, by use of an electric four wheeler indoors.

Do not ride at night or when visibility is limited.

PROPER RIDING ATTIRE

Always wear proper protective equipment, such as an approved safety helmet (with chin strap securely buckled), elbow pads and kneepads. A helmet may be legally required by local law or regulation in your area. A long-sleeved shirt, long pants and gloves are recommended. Always wear athletic shoes (lace-up shoes with rubber soles), and keep shoelaces tied and out of the way of the wheels, brake, motor and drive system. Never ride barefooted or in sandals.

SAFETY WARNINGS

USING THE CHARGER

The charger supplied with the electric four wheeler should be regularly examined for damage to the cord, plug, enclosure and other parts, and in the event of such damage, the four wheeler must not be charged until the charger has been repaired or replaced.

Use only with the recommended charger.

Use caution when charging.

The charger is not a toy. Charger should be operated by an adult.

Do not operate charger near flammable materials.

Unplug charger and disconnect from scooter when not in use.

Always disconnect from the charger prior to wiping down and cleaning your Dirt Quad with a damp cloth.

FAILURE TO USE COMMON SENSE AND HEED THE ABOVE WARNINGS FURTHER INCREASES RISK OF SERIOUS INJURY. USE AT YOUR OWN RISK AND WITH APPROPRIATE AND SERIOUS ATTENTION TO SAFE OPERATION. USE CAUTION.

BEFORE YOU BEGIN

Remove contents from box. Remove the separators that protect the components from damage during shipping. Inspect the contents of the box for scratches in the paint, dents or kinked cables that may have occurred during shipping. Because the Dirt Quad is 95 percent assembled and packed at the factory, there should not be any problems, even if the box has a few scars or dents.

MAKE SURE POWER SWITCH IS TURNED "OFF" BEFORE CONDUCTING ANY ASSEMBLY OR MAINTENANCE PROCEDURES.

Estimated Assembly and Set-Up Time

Razor recommends assembly by an adult.

Allow up to 20 minutes for assembly, not including initial charge time.

Allow up to 12 hours for initial charge (**see page 6 for charging information**).

(Note: Charger design may vary from one shown)

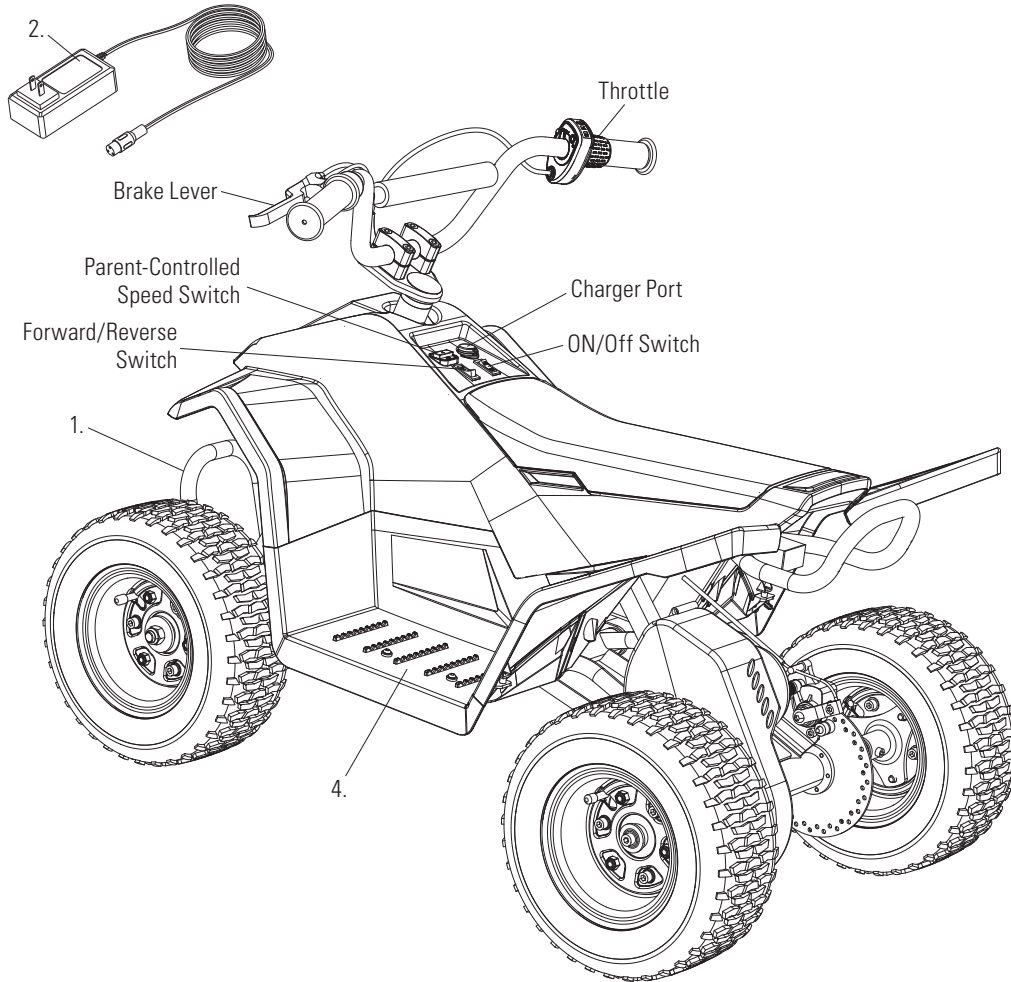

Required Tools

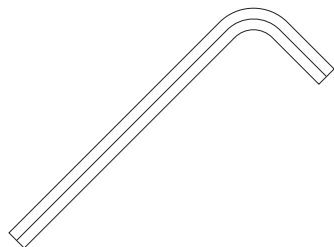

5 mm and 6 mm Allen Wrenches
(included)

NOTE: The Allen Wrench is not a toy. Please store it where the child cannot access it.

WARNING: DO NOT USE NON-RAZOR PRODUCTS WITH YOUR RAZOR DIRT QUAD. The Dirt Quad has been built to certain Razor design specifications. The original equipment supplied at the time of sale was selected on the basis of its compatibility with the frame, fork and all other parts. Certain aftermarket products may or may not be compatible and may void your warranty.

Product ID Locations:
(See locations to the left)

1. Frame (Front)
2. Charger
3. Box (Not Shown)
4. Footrest (Left Side)

Plastic Bag Contents:

- Charger
- Allen Wrenches
- Owner's Manual
- Handlebar Clamps

Need Help? Visit our website for replacement parts, product support, a list of authorized service centers in the US and customer service contact information at www.razor.com. Please have the product I.D. code (located on the white label of your product) available for better assistance. Additional Customer Service contact information is listed at the back of this manual.

ASSEMBLY AND SET-UP

Turn power switch off before conducting any assembly or maintenance procedures.

□ Attaching the Handlebars

Required Tool: 6 mm Allen Wrench (included)

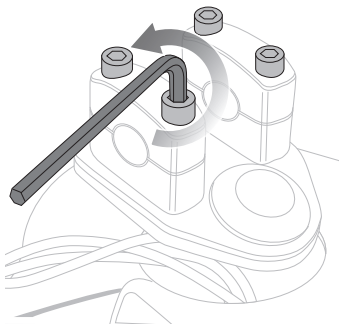

1 Using a 6 mm Allen wrench, remove bolts from handlebar clamp.

Note: Handlebar clamps are located in the plastic bag with owner's manual and charger.

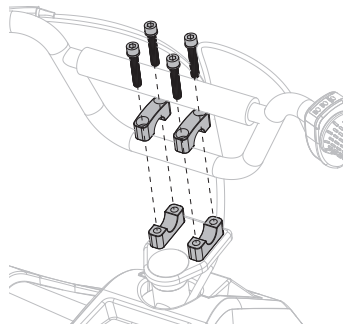

2 Place handlebars in handlebar clamp in upright, vertical position.

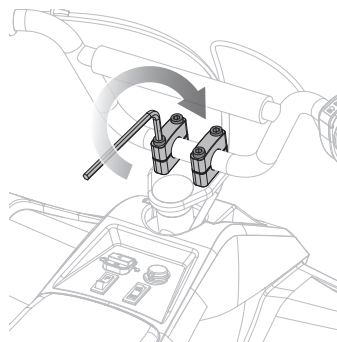

3 Insert bolts and tighten securely, using a 6 mm Allen wrench. When properly tightened, the handlebars should not move forward or back.

Note: The gap between the upper clamp and lower clamp should be equal on both sides of handlebar.

□ Inflating the Tires

Tires are inflated when shipped, but they invariably lose some pressure between the point of manufacturing and your purchase. Inflate the tires to the correct PSI before first time use.

Lower air pressure can result in a shorter ride time.

Periodically check all four tires. Reinflate when needed.

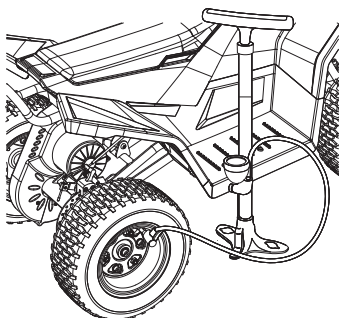

Using a bicycle tire pump equipped for a Schrader valve, inflate the tires to the PSI indicated on the sidewall of the tire.

□ Testing the Brake

To use the brake, squeeze the brake lever to increase the pressure on the brake. The brake lever is fitted with a cable adjuster to compensate for cable stretch and/or to fine-tune the lever movement to brake engagement. If brake is not engaging properly, follow instructions for adjusting the brake outlined on page 8.

⚠ WARNING: Failing to properly adjust and tighten the bolts that affix the handlebars can cause you to lose control and crash.

⚠ WARNING: Do not use the Dirt Quad for the first time until you have inflated the tires to the correct PSI. Failure to do so may damage your Dirt Quad and void your warranty.

⚠ WARNING: Do not over inflate, as this could damage the tire or wheel.

Note: The pressurized air supplies found at gasoline stations are designed to inflate high-volume automobile tires. If you decide to use such an air supply to inflate your tires, first make sure the pressure gauge is working, then use very short bursts to inflate to the correct PSI. If you inadvertently over inflate the tire, release the excess pressure immediately.

Need Help? Visit our website for replacement parts, product support, a list of authorized service centers in the US and customer service contact information at www.razor.com. Please have the product I.D. code (located on the white label of your product) available for better assistance. Additional Customer Service contact information is listed at the back of this manual.

ASSEMBLY AND SET-UP

□ Parent Controlled HIGH/LOW Speed Switch

Required Tool: Phillips Screwdriver (not included)

The Dirt Quad features a speed control switch that allows parents to discreetly reduce (or raise) the Dirt Quad's top speed. This limiter is intended for parents of those needing extra practice time to learn how the Dirt Quad moves. It is recommended that all riders use the LOW setting while learning how to operate the Dirt Quad. Once the rider is comfortable with using the Dirt Quad in the LOW setting, and has acquired the necessary skills to safely ride the Dirt Quad, the parent has the option to change the setting to the HIGH setting.

The switch is inside the Dirt Quad's speed control switch cover, such that riders cannot access it without using a Phillips screwdriver. There are two settings:

- When the switch is in the HIGH position **(A)**, the Dirt Quad has a top speed of 8 mph (13 km/h).
- When the switch is in the LOW position **(B)**, the Dirt Quad's top speed is limited to 5 mph (8 km/h). This is the default setting.

Note: The speed switch is located near the charger port.

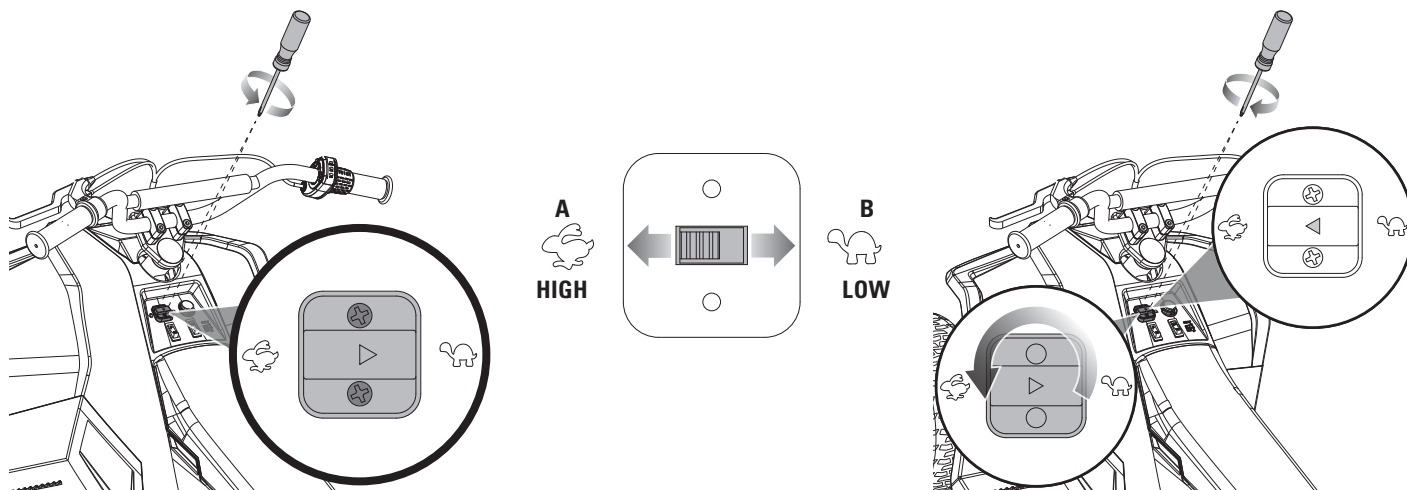

1 Using a Phillips screwdriver, remove the two (2) screws from the speed switch cover and set aside.

2 Move the switch to the left for HIGH speed mode **(A)** or to the right for LOW speed mode **(B)**.

3 Rotate the cover so the arrow is facing the direction of the selected speed setting and replace the two (2) screws with a Phillips screwdriver.

CHARGING THE BATTERY

Your Dirt Quad may not have a fully charged battery; therefore you must charge the battery prior to use.

- Initial charge time: 12 hours.
- Recharge time: up to 12 hours, even if the light turns green. Recommended maximum charging time is 24 hours.
- Always charge the battery immediately after riding.
- Fully charge battery before storing for extended periods of time.
- Unplug charger from the wall outlet when not in use.
- Failure to recharge battery periodically may result in a battery that will not accept a charge.
- Make sure the Dirt Quad's power switch is turned **OFF** when unit is not in use. If the power switch is left on for an extended period of time, the battery may reach a stage at which it will no longer hold a charge.
- To ensure long battery life, never store the product in freezing or below freezing temperatures! Freezing will permanently damage the battery.
- Run time: Up to 40 minutes of continuous ride time. Run time may vary depending on riding conditions, rider weight, climate, and/or proper maintenance.
- Constant stopping and starting may shorten ride time.
- Battery life can vary depending on proper maintenance and usage of the unit.
- Only use the battery(ies) specified by the manufacturer.
- Do not mix old and new batteries.
- Do not mix alkaline, standard (carbon-zinc), or re-chargeable batteries.

⚠ WARNING: Use **ONLY** with the recommended charger. Batteries are only to be charged under adult supervision. The charger is not a toy. Always disconnect the charger before wiping down and/or cleaning the Dirt Quad with a damp cloth.

The charger supplied with the Dirt Quad should be regularly examined for damage to the cord, plug, enclosure and other parts. In the event of such damage, the Dirt Quad must not be charged until it has been repaired or replaced.

Chargers have built-in overcharge protection to prevent battery from being overcharged.

Note: If the charger gets warm during regular use, this is a normal response and is no cause for concern. If your charger does not get warm during use, it does not mean that it is not working properly.

Wall outlet - Green (Stand By)
Wall outlet and Unit - Red (Charging)
Charging complete - Green (Charged)

Note: Continue charging unit even if light turns green prior to 12 hours.

⚠ WARNING: Failure to recharge the battery at least once a month may result in a battery that will no longer hold a charge.

Charger

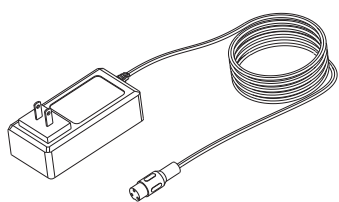

Charger

(Note: Charger design may vary from one shown)

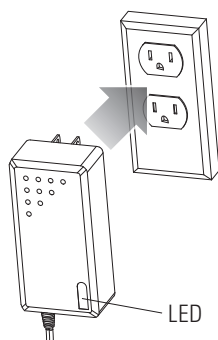

1 Plug the charger plug into wall outlet. The light on the charger should be green.

Note: If green light (LED) does not turn on, try a different outlet.

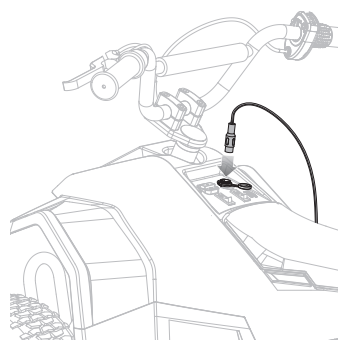

2 Make sure the power switch is in the **OFF** position. Plug the charger into the charger port on the Dirt Quad. The light on the charger should turn red during charging. The light will turn green again when charging is complete.

PRE-RIDE CHECKLIST



Brake

Check the brake for proper function. When you squeeze the brake lever, the brake should provide positive braking action. When you apply the brake with the speed control on, the brake cut-off switch will stop the motor.



Tires

Periodically inspect the tires for excess wear and replace as needed. Regularly check the tire pressure and inflate as needed. If you get a flat tire, the inner tube can be patched or a new tube can be purchased from Razor or an authorized repair center.



Frame, Fork and Handlebars

Check for cracks or broken connections. Although broken frames are rare, it is possible for an aggressive rider to run into a curb or object and wreck, bend or break the frame. Get in the habit of inspecting your product on a regular basis.



Hardware/Loose Parts

Check and secure all fasteners before every ride. There should not be any unusual rattles or sounds from loose parts or broken components. If the unit is damaged, do not ride. **Reference "Safety Warnings" on page 1-2 of this manual.**



Safety Gear

Always wear proper protective gear, such as an approved safety helmet. Elbow pads, kneepads, pants and long sleeves are recommended. Always wear closed toe shoes (lace-up with rubber soles) and keep shoelaces tied and out of the way of the wheels, motor and drive system. **NEVER RIDE BAREFOOTED OR IN SANDALS.**



Laws and Regulations

Always check and obey any local laws or regulations.



Insurance

Do not assume that your existing insurance policies necessarily provide coverage for electric product use. Check with your insurance company for information regarding insurance.



Storage

Prolonged exposure to UV rays, rain and the elements may damage the enclosure materials, store indoors when not in use.

USAGE

□ How to Start

Do not activate the twist-grip throttle unless you are on the product and in a safe, outdoor environment suitable for riding.

To start the product, position your body in the seat and place one foot on each footrest. Turn power switch to the **ON** position (**A**).

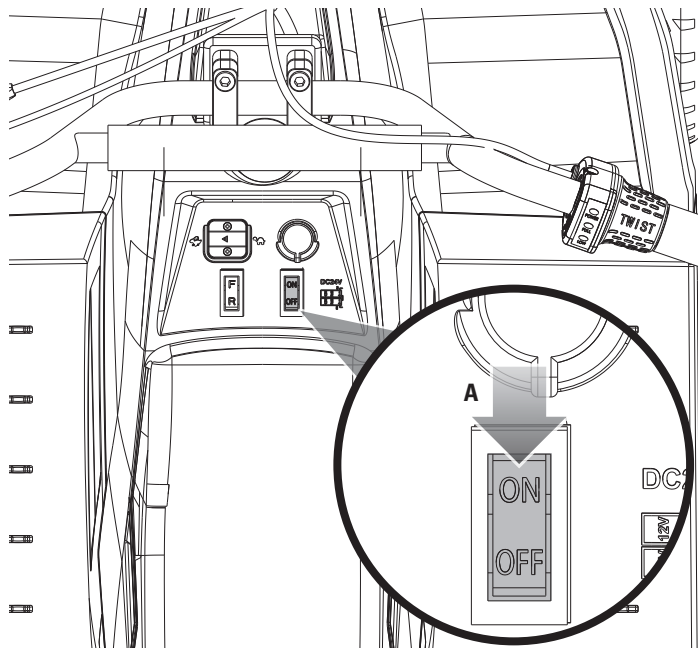

□ How to Drive Forward

Press the direction switch to the **F** (forward) position (**C**). Accelerate with your right hand by twisting the throttle (**A**) to move forward. Brake with your left hand by squeezing the brake lever (**B**). Hold the handlebars with both hands, at all times, to control direction and turning.

Note: Keep both hands on the handlebars and both feet on the footrests when product is in motion.

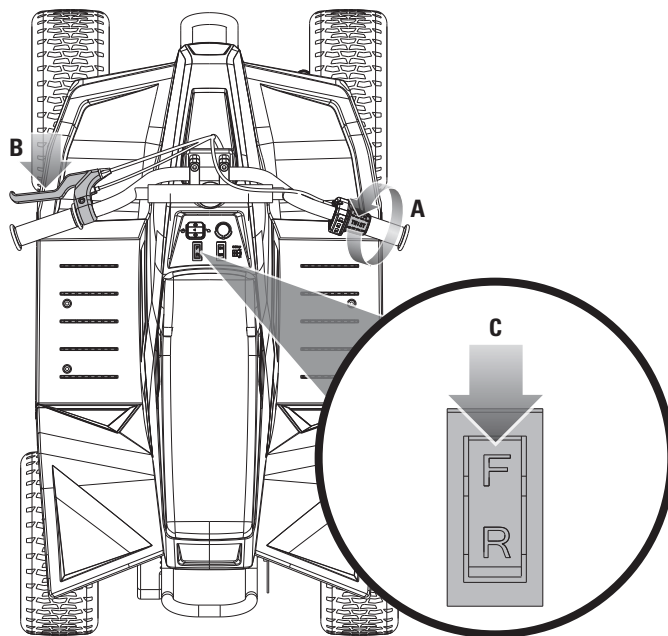

□ How to Stop

To stop the product, release the throttle (**A**), and apply the brake, by squeezing the brake lever (**B**), until the product comes to a **complete stop**. Razor recommends that you practice applying the brake at various speeds and in an open area free from obstructions before riding your product around others. Make sure to press the power switch to the **OFF** position after you complete your ride.

Note: As an additional safety feature, the Dirt Quad is designed to cut power to the motor when the hand brake is applied. In an emergency, applying the brake will always stop the product from moving.

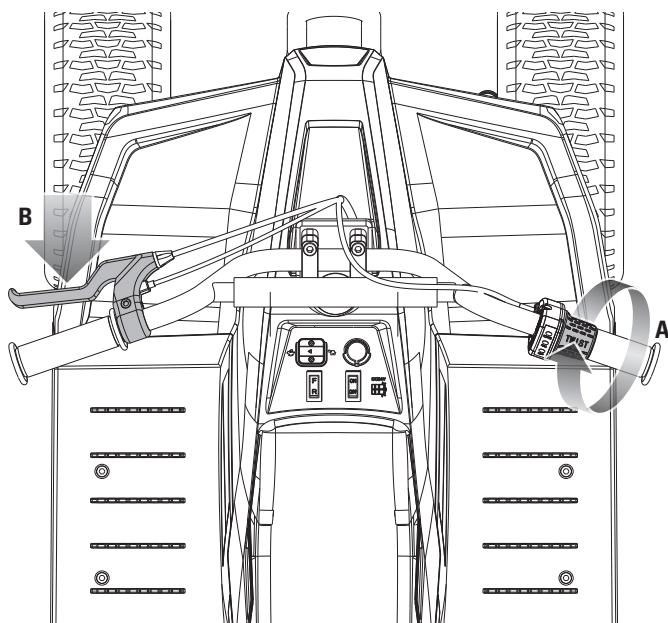

□ How to Drive in Reverse

While fully stopped, press the direction switch to the **R** (reverse) position (**D**). Accelerate with your right hand by twisting the throttle (**A**) to move in reverse. Brake with your left hand by squeezing the brake lever (**B**). Hold the handlebars with both hands, at all times, to control direction and turning. Make sure you look behind you when riding in reverse. Razor recommends that you practice driving in reverse in an open area free from obstructions before riding your product around others.

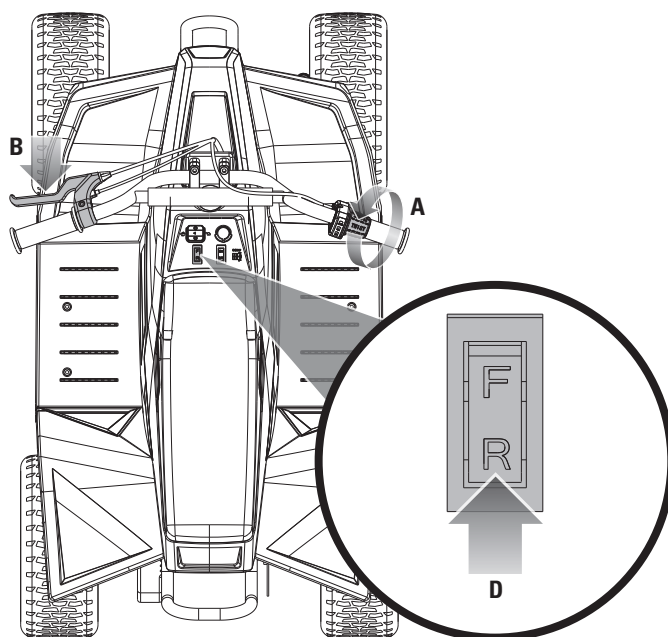

Need Help? Visit our website for replacement parts, product support, a list of authorized service centers in the US and customer service contact information at www.razor.com. Please have the product I.D. code (located on the white label of your product) available for better assistance. Additional Customer Service contact information is listed at the back of this manual.

REPAIR AND MAINTENANCE

Turn power switch "OFF" before conducting any repair or maintenance procedures.

- Read the instructions.
- Remove charger plug.
- Turn the power switch **OFF**.
- Secure the unit under repair.
- Exercise caution around exposed parts.
- Contact Razor customer service if unsure about any repair or maintenance.
- Repair and maintenance should be performed by an adult only.

□ Adjusting the Brake

Required Tool: 5 mm Allen Wrench (included)

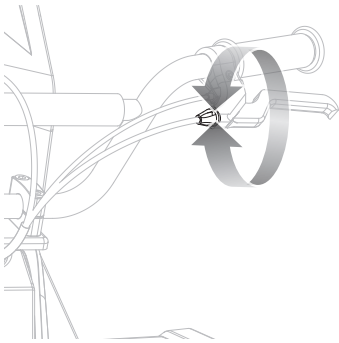

1 To adjust the tension, thread the brake lever adjuster in or out 1/4 to 1/2 turn until the desired brake adjustment is attained. Most adjustments are complete at this step. If brake still needs further adjustment, proceed to step 2 for rear brake.

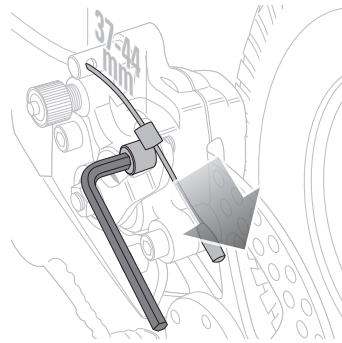

2 Locate the rear brake caliper and disc brake behind the right rear wheel. The distance of the brake wire between the end of the cable and the anchor bolt should be between 37 and 44 mm. If the rear brake has too much slack, loosen the rear anchor bolt with a 5 mm Allen wrench and pull the brake wire tighter (direction indicated with arrow).

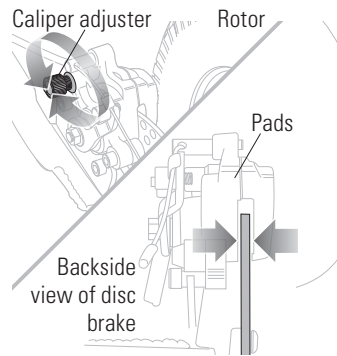

3 If the brake rotor is dragging on the brake pads use your fingers to twist the caliper adjuster in either direction until rotor is centered between pads.

⚠ WARNING: The brake is capable of causing the electric four wheeler to skid the tire throwing an unsuspecting rider. Practice in an open area free from obstacles until you are familiar with the brake function. Avoid skidding to a stop as this can cause you to lose control or damage the rear tire(s).

Note: The brake lever contains a safety switch to cut power to the motor when the brake is applied. In an emergency, applying the brake will always stop the product from moving. Do not disable or replace this brake lever with anything other than a genuine Razor replacement part.

□ Replacing the Fuse

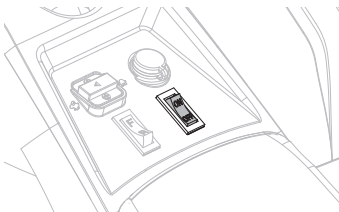

1 Make sure the power switch is turned **OFF**.

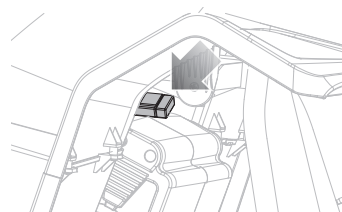

2 Under the front fender and through the frame, locate the fuse box attached to the top of the battery.

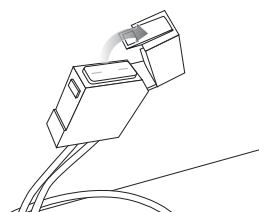

3 Open the fuse cover to expose the fuse.

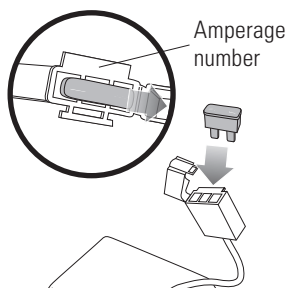

4 Remove the fuse and replace with a new one of equal amperage.

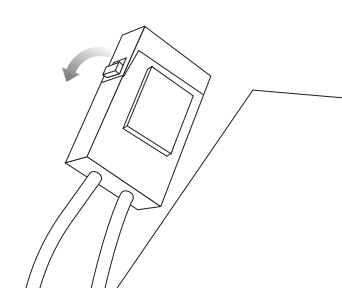

5 Close the fuse cover.

Note: Amperage rating is located on top of fuse.

⚠ WARNING: To prevent shock, please follow the instructions accordingly and do not skip or combine any steps.

RISK OF FIRE. Do not bypass. Replace only with 30A fuse. Razor part number W15128040102.

Need Help? Visit our website for replacement parts, product support, a list of authorized service centers in the US and customer service contact information at www.razor.com. Please have the product I.D. code (located on the white label of your product) available for better assistance. Additional Customer Service contact information is listed at the back of this manual.

REPAIR AND MAINTENANCE

□ Replacing the Chain

Required Tools: 6 mm Allen Wrench, 5 mm Allen Wrench (included) and 10 mm Wrench, Phillips Screwdriver (not included)

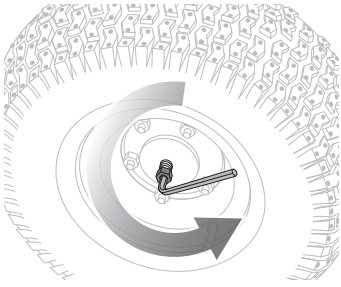

1 Using a 6 mm Allen wrench, remove the bolt and washers on the outside of the rear wheel.

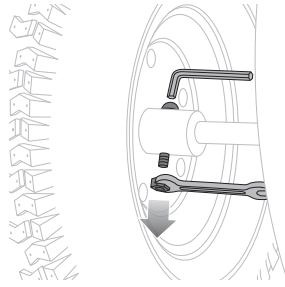

2 Using a 5 mm Allen wrench and a 10 mm wrench, remove the bolt on the inside of the rear wheel. Remove nut and pull bolt out of axle.

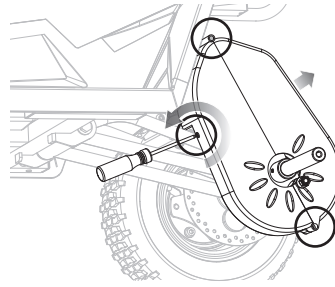

3 Using a Phillips screwdriver, remove the three (3) screws from the chain guard and remove.

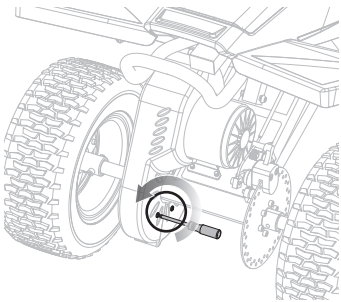

4 Using a Phillips screwdriver, remove the two (2) screws from the chain guard and remove.

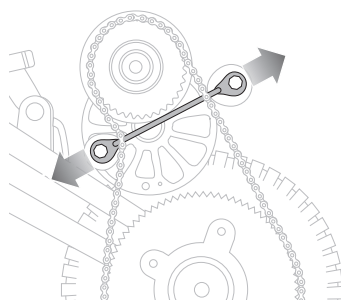

5 Spread the chain tensioner apart to loosen chain.

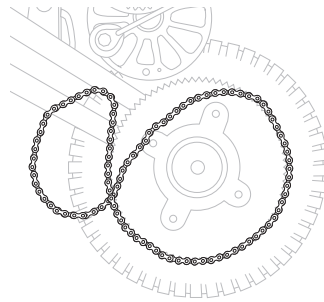

6 Remove chain from both sprockets and replace with new chain.

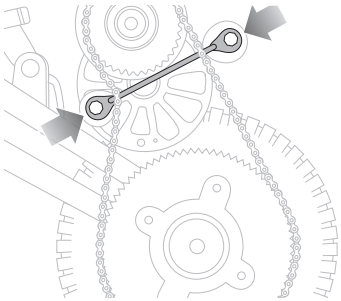

7 Reset chain tensioner.

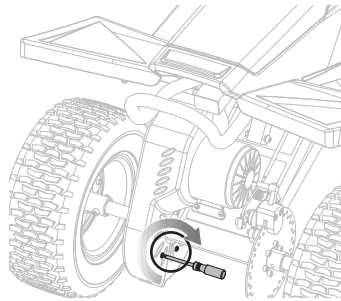

8 Position the chain guard to align mounting holes and, using a Phillips screwdriver, screw to frame.

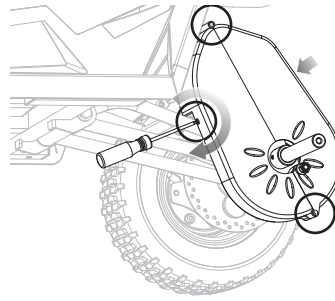

9 Position the chain guard to align mounting holes and, using a Phillips screwdriver, screw to frame.

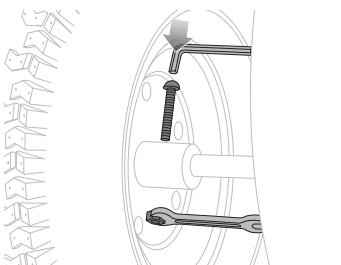

10 On the inside of the wheel slide bolt through wheel and axle and, using a 5 mm Allen wrench and a 10 mm wrench, secure with nut.

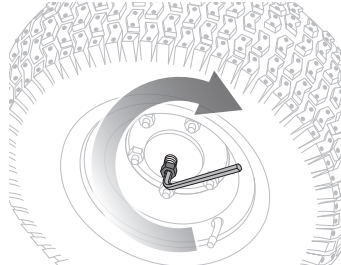

11 On the outside of the wheel replace washers and, using a 6 mm Allen wrench, secure with bolt.

⚠ WARNING: Do not touch motor after use. Motor is (or can be) very hot.

REPAIR AND MAINTENANCE

❑ Chain and Sprocket

The chain will typically have a "loose spot" and "tight spot" corresponding with a particular sprocket rotational position. This is normal and common to all chain-driven products due to run-out tolerances of the freewheel and sprocket. Proper chain alignment must be maintained. If the chain is noisy or rough running, check the lubrication, tension and alignment of the sprockets, in that order. The chain tensioner must be aligned and free from binding and the tensioner spring(s) must be operating correctly.

❑ Battery Care and Disposal

Do not store in freezing or below freezing temperatures. To properly maintain your battery and ensure maximum battery life, carefully read the "Charging the Battery" section on page 6 of this owner's manual.



CONTAINS SEALED LEAD-ACID BATTERIES. BATTERIES MUST BE RECYCLED.

Disposal: Your Razor product uses sealed lead-acid batteries which must be recycled or disposed of in an environmentally safe manner. Do not dispose of a lead-acid battery in a fire. The battery may explode or leak. Do not dispose of a lead-acid battery in your regular household trash. The incineration, land filling or mixing of sealed lead-acid batteries with household trash is prohibited by law in most areas. Return exhausted batteries to a federal or state approved lead-acid battery recycler or a local seller of automotive batteries. If you live in Florida or Minnesota, it is prohibited by law to throw away lead-acid batteries in the municipal waste stream.

❑ Charger

The charger supplied with the Dirt Quad should be regularly examined for damage to the cord, plug, enclosure and other parts, and in the event of such damage, the product must not be charged until it has been repaired or replaced.

Use ONLY with the recommended charger.

❑ Wheels

Wheels and drive system are subject to normal wear and tear. It is the responsibility of the user to periodically inspect wheels for excess wear and adjust and replace drive train components as required.

❑ Replacement Parts

The most frequently requested replacement parts are available for purchase at some Razor retail partners. For the complete selection of replacement parts visit www.razor.com.

❑ Repair Centers

For a list of authorized Razor repair centers:

- Check online at www.razor.com.
- Additional Customer Service contact information is listed on the back of this manual.

⚠ WARNING: To avoid a pinch or injury, keep fingers away from moving sprockets and chain.



In the US and Canada only:

For more information regarding recycling of rechargeable batteries, call toll free 1-800-822-8837, or visit <http://www.call2recycle.org>

⚠ WARNING: If a battery leak develops, avoid contact with the leaking acid and place the damaged battery in a plastic bag. Refer to the disposal instructions at left. If acid comes into contact with skin or eyes, flush with cool water for at least 15 minutes and contact a physician.

⚠ WARNING: Battery posts, terminals and related accessories contain lead and lead compounds. **Wash your hands after handling.**

TROUBLESHOOTING GUIDE

Product should be fully charged prior to doing any troubleshooting and must be done by an adult ONLY.

Problem	Possible Cause	Solution
Product does not run	Product is rolling backwards	Throttle will not engage if the product is rolling backwards. Come to a complete stop and then activate the throttle.
	Undercharged battery	Charge the battery. A new battery should have been charged for at least 12 hours before using the product for the first time and up to 12 hours after each subsequent use. Check all connectors. Make sure the charger connector is tightly plugged into the charging port, and that the charger is plugged into the wall.
Product suddenly stopped working while in use	Loose wires or connectors	Check all wires and connectors to make sure they are tight.
	Burned-out fuse	The fuse will burn out and automatically shut off the power if the motor is overloaded. An excessive overload, such as too heavy a rider or too steep a hill, could cause the motor to overheat. Refer to replacing the fuse instructions on page 8 of this manual. Correct the conditions that caused the fuse to burn out and avoid repeatedly burning out fuse.
	Motor or electrical switch damage	Contact your local Razor authorized service center for diagnosis and repair.
Short run time (less than 15 minutes per charge)	Undercharged battery	Charge the battery. A new battery should have been charged for at least 12 hours before using the product for the first time and up to 12 hours after each subsequent use. Check all wires and connectors. Make sure the battery connector is tightly plugged into the charger connector, and that the charger is plugged into the wall.
	Brake is not adjusted properly	Refer to brake adjustment instructions on page 8 of this manual.
Product runs sluggishly	Riding conditions are too stressful	Use only on solid, flat clean and dry surfaces such as pavement or level ground.
	Tires are not properly inflated	The tires are inflated when shipped, but they invariably will lose some pressure between the point of manufacturing and your purchase. Refer to instructions on page 4 of this manual to properly inflate tires.
	Product is overloaded	Make sure you do not overload the product by allowing more than one rider at one time, exceeding the maximum weight limit, going up too steep a hill or towing objects behind the product.
Sometimes the product doesn't run, but other times it does	Loose wires or connectors	Check all wires around the motor and all connectors to make sure they are tight.
	Motor or electrical switch damage	Contact your local Razor authorized service center for diagnosis and repair.
Product makes loud noises or grinding sounds	Chain is too dry	Apply a lubricant such as 3 in 1™ or Tri-Flow™ to the chain.

For more troubleshooting tips, a list of available replacement parts or to locate an authorized Service Center in your area, visit our website at www.razor.com or call toll free +1 866 467 2967 to speak to a live Customer Service Representative.

Need Help? Visit our website for replacement parts, product support, a list of authorized service centers in the US and customer service contact information at www.razor.com. Please have the product I.D. code (located on the white label of your product) available for better assistance. Additional Customer Service contact information is listed at the back of this manual.

DIRT QUAD PARTS

Keep your Dirt Quad running for years with genuine Razor parts. Visit our website or e-mail us for more information on spare part availability. (Specifications subject to change without notice.)

- | | |
|--------------------------------------|--------------------------------------|
| 1. Handlebar Grips (Right/Left) | 12. Chain Tensioner |
| 2. Throttle
2-1 Sleeve | 13. Battery Cover (Right/Left) |
| 3. Handlebar | 14. Rear Wheel Complete (Right/Left) |
| 4. Brake Lever Assembly | 15. Caliper Brake |
| 5. Handlebar Clamps (x2) | 16. Disc Brake |
| 6. Frame Brace | 17. Chain |
| 7. Front Wheel Complete (Right/Left) | 18. Sprocket |
| 8. Adjustable Tie Rod | 19. Chain Guard (Upper/Lower) |
| 9. Control Module | 20. Plastic Body with Seat |
| 10. Battery (2-12V/7Ah) w/Fuse | 21. On/Off Switch |
| 11. Motor (350W) | 22. Charger Port |
| | 23. Forward (F)/Reverse (R) Switch |

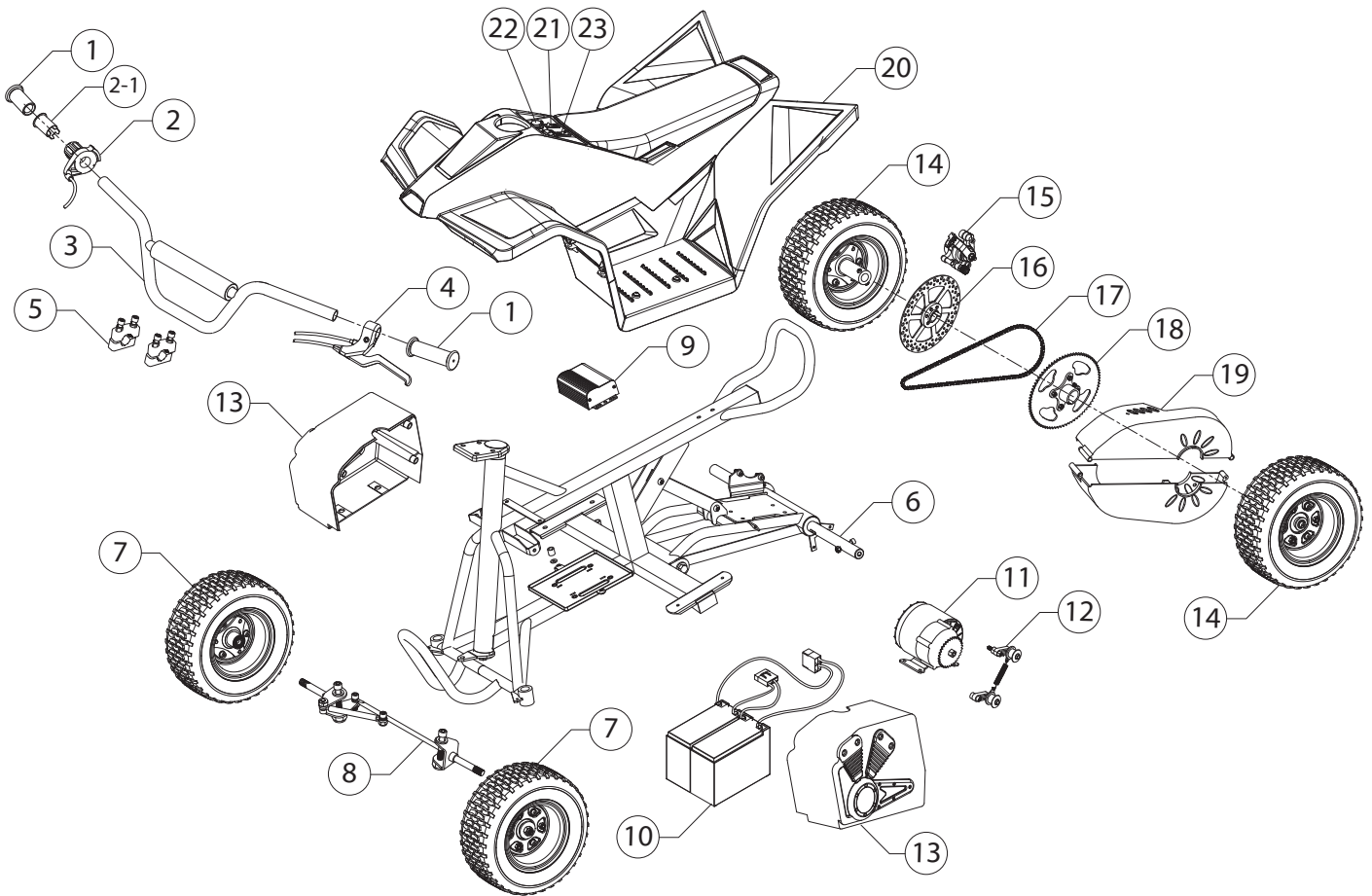

Need Help? Visit our website for replacement parts, product support, a list of authorized service centers in the US and customer service contact information at www.razor.com. Please have the product I.D. code (located on the white label of your product) available for better assistance. Additional Customer Service contact information is listed at the back of this manual.

NOTICE: INSURANCE

YOUR INSURANCE POLICIES MAY NOT PROVIDE COVERAGE FOR ACCIDENTS INVOLVING THE USE OF THIS SCOOTER/ELECTRIC RIDE-ON PRODUCT. TO DETERMINE IF COVERAGE IS PROVIDED, YOU SHOULD CONTACT YOUR INSURANCE COMPANY OR AGENT.

FCC COMPLIANCE

This device complies with Part 15 of the FCC Rules. Operation is subject to the following two conditions: (1) This device may not cause harmful interference, and (2) this device must accept any interference received, including interference that may cause undesired operation.

Note: This equipment has been tested and found to comply with the limits for a Class B digital device, pursuant to part 15 of the FCC Rules. These limits are designed to provide reasonable protection against harmful interference in a residential installation. This equipment generates, uses and can radiate radio frequency energy and, if not installed and used in accordance with the instructions, may cause harmful interference to radio communications. However, there is no guarantee that interference will not occur in a particular installation. If this equipment does cause harmful interference to radio or television reception, which can be determined by turning the equipment off and on, the user is encouraged to try to correct the interference by one or more of the following measures:

- Reorient or relocate the receiving antenna.
- Increase the separation between the equipment and receiver.
- Connect the equipment into an outlet on a circuit different from that to which the receiver is connected.
- Consult the dealer or an experienced radio/TV technician for help.

⚠ WARNING: Changes or modifications to this unit not expressly approved by Razor USA, could void the user's authority to operate the equipment.

WARRANTY

Razor Limited Warranty

The manufacturer warrants this product to be free of manufacturing defects for a period of 90 days from date of purchase. This Limited Warranty does not cover normal wear and tear, tire, tube or cables, or any damage, failure or loss caused by improper assembly, maintenance, storage or use of the Razor Dirt Quad.

This Limited Warranty will be void if the product is ever:

- used in a manner other than for recreation or transportation;
- modified in any way;
- rented.

The manufacturer is not liable for incidental or consequential loss or damage due directly or indirectly to the use of this product.

Razor does not offer an extended warranty. If you have purchased an extended warranty, it must be honored by the insurance provider from which it was purchased.

For your records, save your original sales receipt with this manual and write the serial number below.

CUSTOMER SERVICE CONTACT INFORMATION

Need Help? Visit our website for product support, a list of authorized service centers in the US and customer service contact information at www.razor.com. Please have the product I.D. code (located on the white label of your product) available for better assistance. Additional Customer Service contact information is listed below:

AMERICAS

Razor USA LLC
P.O. Box 3610
Cerritos, CA 90703
USA

+1 866 467 2967
Monday - Friday
8:00 AM - 5:00 PM Pacific Time
customersupport@razorusa.com

EUROPE, MIDDLE EAST, AFRICA

Razor USA LLC (Europe)
Handelsweg 2
2742 RD Waddinxveen
Netherlands

+44 (0) 120 267 2702
info@razoreu.com

ASIA

Razor USA LLC (Asia)
P.O. Box 3610
Cerritos, CA 90703
USA

+81 50 7579 6622
info@razor-asia.com

UNITED KINGDOM AND IRELAND

Razor USA LLC (UK)
Unit 20
Hartnoll Business Centre
Post Hill, Tiverton
Devon EX16 4NG
UK

+44 (0) 120 267 2702
info@razoreu.com

AUSTRALIA AND NEW ZEALAND

Razor USA LLC
P.O. Box 4280
Auburn South
VIC 3122
Australia

+1 800 954 354 (AU)
+0 800 003 221 (NZ)
info@razoranz.com

IMPORTED IN JAPAN BY B-PLUS ASIA CORP.

Razor USA LLC
THE RIRSTIK COMPANY
Kurokawa 3-1, Asaoku,
Kawasaki, Kanagawa
215-0035 JAPAN

+81 (0) 44 328 9057 Tel
+81 (0) 44 328 9067 Fax
info@razor-asia.com

Printed in China for Razor USA LLC.

Copyright ©2003-2024 Razor USA, LLC. All rights reserved. Razor® and the Razor logo design are among the registered trademarks of Razor USA LLC in the United States and/or select foreign countries. Dirt Quad logo design is a trademark of Razor USA LLC.