



# E200 (V.13+) and E300 (V.11 & V.13+) ELECTRIC SCOOTER CONTROL MODULE INSTALLATION INSTRUCTIONS

**NOTE:** If you received a control module AND throttle, make sure to replace BOTH parts on your unit.

## Tools Required: (Not included)

- A. Phillips head screwdriver
- B. 4mm Allen wrench
- C. 8mm open wrench

**⚠ CAUTION:** To avoid potential shock or other injury, turn power switch OFF and disconnect charger before removing or installing the batteries. Failure to follow these steps in the correct order may cause irreparable damage.

### Step 1

Using a Phillips head screwdriver, remove the four screws in the front of the deck. Using a phillips head screwdriver and 8mm open wrench, remove the two screws and locknuts in the back of the deck. Using a 4mm Allen wrench remove the two hex bolts. Remove deck plate.

**Note:** If you are having difficulty removing the screws, use pliers to twist the screw out from the bottom.

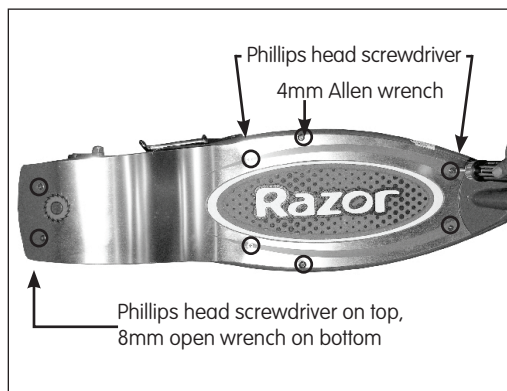

Figure 1

### Step 2

Using a Phillips head screwdriver, remove the screws on the battery bracket and remove bracket.



Figure 2

### Step 3

Locate the white plastic connector on the battery. Cut the zip tie and discard it. Disconnect the white plastic connectors attached to the battery and control module by depressing the tab.

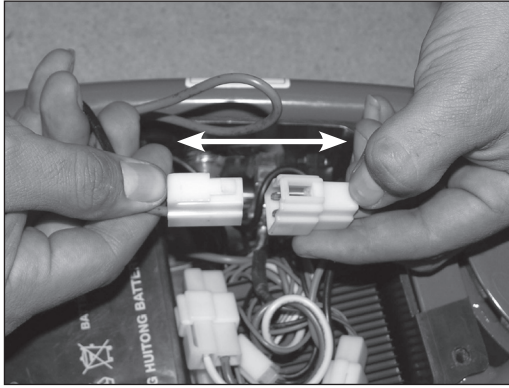

Figure 3

### Step 4

Follow the single black and red wires on the battery to the reset button and gently unplug both wires from the reset button.

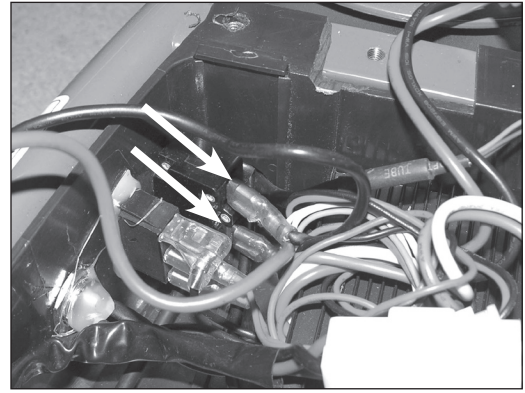

Figure 4

### Step 5

Carefully lift the batteries out of the battery tray, one battery at a time.



Figure 5

### Step 6

Disconnect the remaining six connectors so that everything is disconnected. Using a Phillips head screwdriver, remove the two screws holding the control module in place and remove.

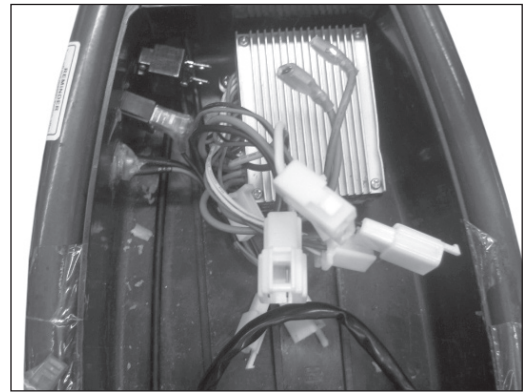

Figure 6

## Step 7

Install the new control module and secure using the same two screws previously removed. Reconnect connectors A, B, C and E in the battery tray to the corresponding connector on the control module (Refer to figure 8). Plug the two red wires on the control module into the two bottom prongs of the power switch (in no particular order). **Note:** Do NOT plug the red wires into the top gold prong of the power switch.

Reconnect connector D on the control module to the battery. Carefully place batteries back into the battery tray, one at a time. Reconnect the single red and black wires on the battery into the reset button (in no particular order).

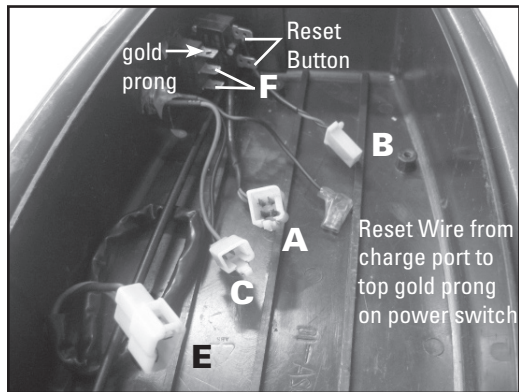

Figure 7

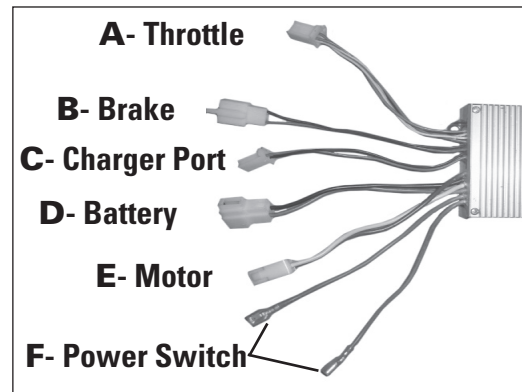

Figure 8

## Before Closing your unit

1. Before reattaching the battery bracket and deck plate, secure your unit. Turn the power switch on and slowly apply the throttle. If unit works, reattach battery bracket and deck plate.
2. If the unit does not work, check to make sure that:
  - The black wire attached to the charger port is plugged into the top gold prong of the power switch directly above the two red wires.
  - All pins are locked securely inside both sides of each white plastic connector.
  - All connectors are locked together securely.
  - Wires to the reset button and power switch are attached securely to the prongs.

**ATTENTION: Charge unit at least 18 hours before riding.**